

Diaphragm Vacuum Pump



255161 (N820G)



Chemically resistant, compact and oil-free diaphragm vacuum pump

■ Features

- Adjustable speed control
- Ideal for extremely aggressive/corrosive gases and vapors
- Clean, 100% oil-free operation

■ Applications

- Rotary evaporator
- Evaporating system
- Vacuum concentrator
- Vacuum filtration
- Vacuum drying systems
- Centrifuge
- Medical / Pharmaceutical equipment
- Analysis / scientific equipment

■ Specifications

Model	255161 (N820G)
Ultimate vacuum (mbar abs.)	
Minimum speed:	
Gas ballast closed	≤ 6
Gas ballast open	≤ 17
Maximum speed:	
Gas ballast closed	≤ 8
Gas ballast open	≤ 15
Flow rate at atm. pressure (l/min)	
Min. speed	9
Max. speed	20
Permissible ambient temperature	+10°C to + 40°C
Diaphragm material	PTFE-coated
Device protection	Overcurrent protection Overtemperature protection (drive) Blocking protection (drive)
Voltage (V)	100-240
Frequency (Hz)	50/60
Max. operating current (A)	0.66
Dimensions LxWxH (mm)	259 x 163 x 220
Weight (kg)	8.8

■ Vacuum Pump Guide

Assembly No.	Components	Applicable products
N820GKIT	N820G Diaphragm Vacuum Pump (255161) Vacuum hose (255297)	All RE Series Rotary Evaporators

■ Pump Materials

Assembly	Material
Pump head	Modified PTFE
Diaphragm	PTFE-coated
Valve	FFPM
Interconnection	PTFE / FFPM
Hose connector	PTFE / FFPM
Gas ballast	PTFE / FFPM

Design

- 1 Pneumatic pump inlet
- 2 Handle
- 3 Rotary / push knob
- * Switching pump on and off
- * Adjusting pump speed
- 4 Pneumatic pump outlet
- 5 Power switch
- 6 Signal cable connection port with cap
- 7 Control knob for gas ballast

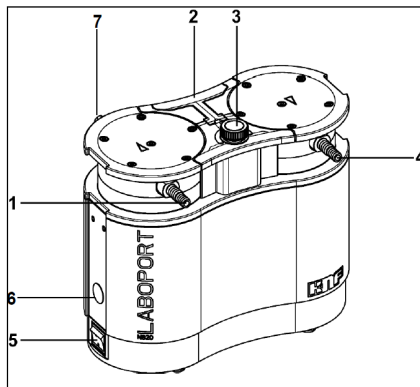

Function Diaphragm Pump

- 1 Outlet valve
- 2 Inlet valve
- 3 Transfer chamber
- 4 Diaphragm
- 5 Eccentric
- 6 Connection rod
- 7 Pump drive

