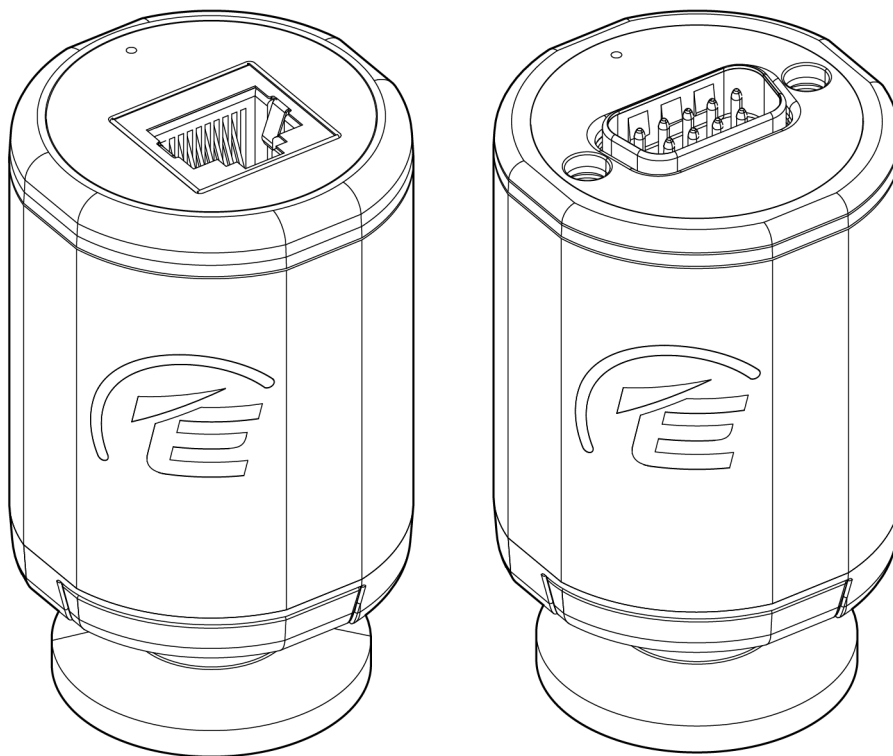




# APG200 Active Pirani Gauge

## INSTRUCTION MANUAL

[edwardsvacuum.com](http://edwardsvacuum.com)



## Copyright notice

©Edwards Limited 2022. All rights reserved.

Published: 6/27/2022

## Trademark credit

Edwards and the Edwards logo are trademarks of Edwards Limited, Innovation Drive, Burgess Hill, West Sussex RH15 9TW.

Swagelok® is a registered trademark of Swagelok Company

VCR® is a registered trademark of Swagelok Company

CONFLAT® is a registered trademark of Agilent Technologies, Inc

## Disclaimer

The content of this manual may change from time to time without notice. We accept no liability for any errors that may appear in this manual nor do we make any expressed or implied warranties regarding the content. As far as practical we have ensured that the products have been designed and constructed to be safe and without risks when properly installed and used in accordance with their operating instructions.

We accept no liability for loss of profit, loss of market or any other indirect or consequential loss whatsoever.

Product warranty and limit of liability are dealt with in our standard terms and conditions of sale or negotiated contract under which this document is supplied.

You must use this product as described in this manual. Read the manual before you install, operate, or maintain the product.

## Numbering matrix

**APG200** —  —  —  —  —

<b>D</b>	<b>1</b>	<b>G</b>							
----------	----------	----------	--	--	--	--	--	--	--

# Contents

<b>1. Safety and compliance.</b> . . . . .	<b>6</b>
1.1 Definition of Warnings and Cautions. . . . .	6
1.2 Safety symbols. . . . .	7
<b>2. Introduction.</b> . . . . .	<b>8</b>
2.1 Description. . . . .	8
2.2 Item number and description matrix. . . . .	9
<b>3. Technical data.</b> . . . . .	<b>12</b>
3.1 Operating and storage conditions. . . . .	12
3.2 Manufacturing materials. . . . .	12
3.3 Performance data. . . . .	12
3.4 Mechanical data. . . . .	13
3.5 Electrical data. . . . .	14
3.5.1 ID resistor. . . . .	15
3.5.2 Pressure output signal. . . . .	15
3.5.3 Setpoint. . . . .	16
<b>4. Installation.</b> . . . . .	<b>17</b>
4.1 Unpack and inspect. . . . .	17
4.2 Install the gauge. . . . .	17
4.3 Connect the gauge. . . . .	18
4.3.1 Connect to the vacuum system. . . . .	18
4.3.2 Connect to the electrical equipment. . . . .	18
4.3.3 Maximum cable length. . . . .	22
<b>5. Operation.</b> . . . . .	<b>23</b>
5.1 LED indicator. . . . .	23
5.2 Pressure measurement. . . . .	24
5.2.1 APG200 with Log linear with pressure output. . . . .	24
5.2.2 Voltage to pressure conversion for APG200. . . . .	24
5.2.3 APG200 with non-linear pressure output. . . . .	27
5.3 Gas dependency. . . . .	29
5.4 Advanced functions. . . . .	31
5.4.1 Setpoint adjustment. . . . .	32
5.5 Operation errors. . . . .	34
5.6 Bakeout. . . . .	35
<b>6. Maintenance.</b> . . . . .	<b>36</b>
6.1 Atmosphere and vacuum adjustment. . . . .	36

6.1.1 Atmosphere adjustment. ....	36
6.1.2 Vacuum adjustment. ....	36
6.1.3 Remote adjustment - APG200 with transistor setpoint [blank] option. .....	36
6.2 Replace the gauge tube. ....	37
<b>7. Fault finding. ....</b>	<b>39</b>
<b>8. Disposal. ....</b>	<b>41</b>
<b>9. Spares. ....</b>	<b>42</b>
<b>10. Accessories. ....</b>	<b>43</b>
<b>11. Service. ....</b>	<b>44</b>
11.1 Return the equipment or components for service .....	44
<b>12. Appendix - Multi-function button operation. ....</b>	<b>45</b>

# List of Figures

Figure 1: General view. . . . .	8
Figure 2: Item description matrix. . . . .	10
Figure 3: Item number matrix. . . . .	11
Figure 4: Dimensions (mm). . . . .	14
Figure 5: Electrical connectors. . . . .	18
Figure 6: 9 way D-sub connector with setpoint transistor. . . . .	20
Figure 7: 9 way D-sub connector with dual relays. . . . .	21
Figure 8: RJ45 connector with setpoint transistor. . . . .	21
Figure 9: RJ45 connector with dual relays. . . . .	22
Figure 10: XM, XMP. . . . .	25
Figure 11: XLC. . . . .	25
Figure 12: "O" output curves. . . . .	26
Figure 13: "G" output curves. . . . .	26
Figure 14: Q, LC variant. . . . .	27
Figure 15: Q, M, MP variants. . . . .	27
Figure 16: Gas dependency of APG200 with M, MP filament/pressure characteristic. . . . .	30
Figure 17: Gas dependency of APG200 with LC filament/pressure characteristic. . . . .	30
Figure 18: Adjustment of APG200. . . . .	32
Figure 19: Replace the gauge tube. . . . .	38
Figure 20: Replacement tube spares. . . . .	42
Figure 21: Replacement electronics housing. . . . .	42
Figure 22: Multi-function button operation. . . . .	45

# 1. Safety and compliance

For safe operation from the start, read these instructions carefully before you install or commission the equipment and keep them safe for future use. Read all the safety instructions in this section and the rest of this manual carefully and make sure that you obey these instructions.

## 1.1 Definition of Warnings and Cautions

Important safety information is highlighted as warning and caution instructions which are defined as follows. Different symbols are used according to the type of hazard.

### **WARNING:**

**If you do not obey a warning, there is a risk of injury or death.**

### **CAUTION:**

**If you do not obey a caution, there is a risk of minor injury, damage to equipment, related equipment or process.**

### **NOTICE:**



**Information about properties or instructions for an action which, if ignored, will cause damage to the equipment.**

We reserve the right to change the design and the stated data. The illustrations are not binding.

## 1.2 Safety symbols

The safety symbols on the products show the areas where care and attention is necessary.

The safety symbols that we use on the product or in the product documentation have the following meanings:

	<p>Warning/Caution An appropriate safety instruction must be followed or caution to a potential hazard exists.</p>
	<p>WEEE symbol The equipment must be discarded carefully. Obey local and national regulations for disposal of this equipment.</p>

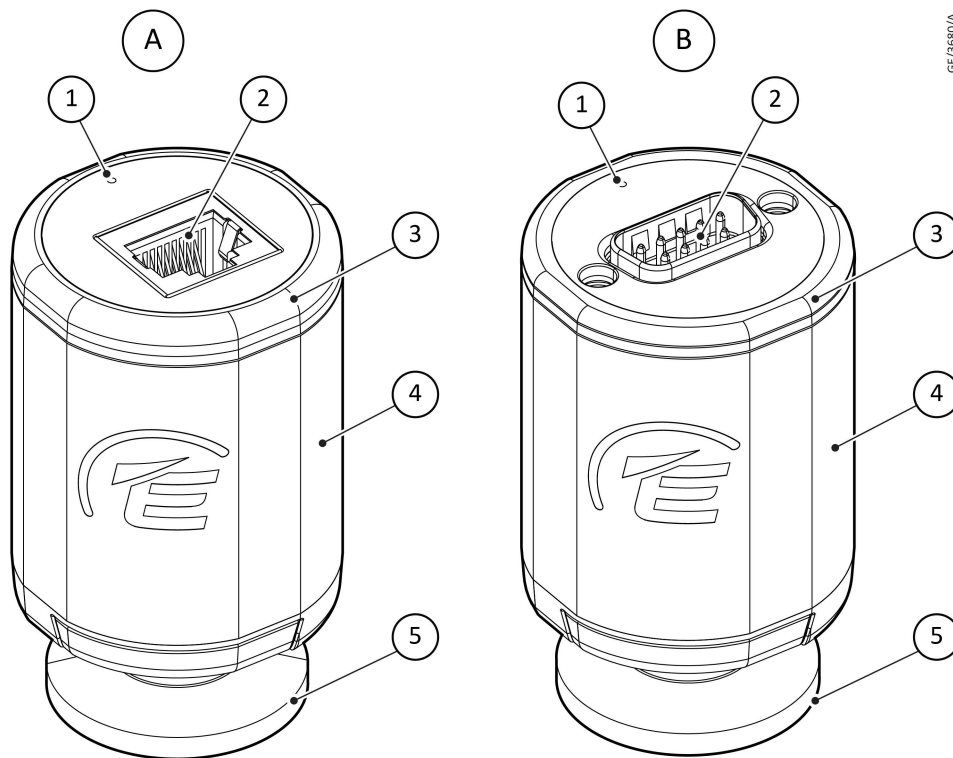
## 2. Introduction

### 2.1 Description

The APG200 Pirani gauge operates on the principle of thermal conductivity in which the rate of heat loss from a heated filament is dependent on the pressure of the gas (around filament). Refer to [Figure: General view](#).

1. The gauge has a detachable tube that allows the replacement of the tube or electronics housing in the event of failure.
2. There is a multi-function button on the top of the gauge for navigation through the various menus within the gauge.
3. An LED indicator surrounding the circumference of the top of the gauge provides a status indication and aids the adjustment of the gauge when you navigate through the menus.
4. The gauge is available with different electrical connectors, voltage scaling and vacuum flanges to integrate with the customer process.

**Figure 1** General view



1. Multi-function button
3. LED indicator
5. Vacuum flange

2. Electrical connector
4. Electronics housing



## 2.2 Item number and description matrix

The range of the pirani gauge is highly configurable. The characteristics of a particular product are defined through the product item number or description. The characteristics in the table that follows can be selected at the point of purchase.

*Table 1 Options*

Characteristic	Description
Voltage output	Different transfer functions including matched voltage outputs to ensure compatibility with most vacuum gauges available on the market
Filament/Pressure range	Different filament materials which have been selected for their ability to measure low pressures and/or their resistance to corrosion
Setpoint	Transistor setpoint or 2 solid state relays
Flange	Different vacuum flanges are available
Connector	Different electrical connectors are available
Other	Gauges can be ordered with calibration certificates

Figure 2 Item description matrix

APG200	X	LC	S	NW25	9 PIN DSUB	CAL
<p><b>Voltage output</b></p> <p>X : 2.0 V to 9.0 V log linear with pressure            G : 1.9 V to 10.0 V log linear with pressure            O : 2.2 V to 8.5 V log linear with pressure            Q : 1.875 V to 8.875 V log linear with pressure            [Blank] : 2.0 to 10.0 V non linear with pressure</p> <p><b>Filament/pressure range</b></p> <p>M : Standard filament            1x10<sup>-3</sup> or 5x10<sup>-4</sup> mbar to 1000 mbar            (model dependent)            LC : Corrosion resistant filament            1x10<sup>-4</sup> or 5x10<sup>-4</sup> mbar to 1000 mbar            (model dependent)            MP : Corrosion resistant filament            1x10<sup>-3</sup> or 5x10<sup>-4</sup> mbar to 1000 mbar            (model dependent)</p> <p><b>Setpoint</b></p> <p>[Blank] : Transistor setpoint            S : 2 solid state relay setpoint</p> <p><b>Flange</b></p> <p>NW16 : NW16 flange            NW25 : NW25 flange            1/8" NPT : 1/8" NPT (male)            4VCR : Swagelok 4VCR fitting (female)            8VCR : Swagelok 8VCR fitting (female)            Bare tube : 1/2" OD tube            DN16CF : DN16 conflat flange</p> <p><b>Connector</b></p> <p>[Blank] : RI45 connector            9 pin DSUB : 9 pin D - subminiature (male)</p> <p><b>Other</b></p> <p>[Blank] : No additional features            CAL : supplied with calibration certificate</p>						

The complete range of available options can be found in the [Item number and description matrix](#) on page 9.

Figure 3 Item number matrix

D	1	G	2	2	2	1	2	0	C
<b>Filament/pressure range</b>									
1 : 1x10 <sup>-3</sup> or 5x10 <sup>-4</sup> mbar to 1000 mbar (model dependent)									
2 : 1x10 <sup>-4</sup> or 5x10 <sup>-4</sup> to 1000 mbar (model dependent) (Corrosion resistant filament)									
3 : 1x10 <sup>-3</sup> or 5x10 <sup>-4</sup> to 1000 mbar (model dependent) (Corrosion resistant filament)									
<b>Setpoint</b>									
0 : Transistor setpoint									
2 : 2 solid state relay setpoint									
<b>Flange</b>									
1 : NW16 flange									
2 : NW25 flange									
5 : 1/8" NPT (male)									
6 : Swagelok 4VCR fitting (female)									
7 : Swagelok 8VCR fitting (female)									
8 : 1/2" OD tube									
9 : DN16 conflat flange									
<b>Connector</b>									
1 : RJ45 connector									
2 : 9 pin D - subminiature (male)									
<b>Voltage output</b>									
Standard output : 1.286 V per decade log linear with pressure									
2 : 1.9 V to 10.0 V log linear with pressure									
3 : 2.2 V to 8.5 V log linear with pressure									
4 : 1.875 V to 8.875 V log linear with pressure									
5 : 2.0 V to 10.0 V log linear with pressure									
<b>Other</b>									
0 : No additional features									
C : Supplied with calibration certificate									

## 3. Technical data

### 3.1 Operating and storage conditions

*Table 2 Operating and storage conditions*

Parameter	Value
Ambient operating temperature range	+5 °C to +60 °C
Ambient storage temperature range	-30 °C to +70 °C
Bakeout temperature	150 °C (with electronics housing removed)
Humidity	80% RH up to 31 °C decreases linearly to 50% RH at 40 °C and above
Maximum altitude	3000 m
Maximum internal pressure	10 bar absolute (9 bar gauge)
Pollution degree	2
Filament temperature	Approximately 100 °C

### 3.2 Manufacturing materials

*Table 3 Materials exposed to vacuum*

Filament/Pressure range characteristic*	Materials exposed to vacuum		
	M	MP	LC
Where used			
Filament Material	Tungsten/Rhenium (standard)	Platinum/Rhodium (corrosion resistant)	Platinum/Iridium (corrosion resistant)
Tube	Stainless Steel 316L and 304L		
Filter	Stainless Steel 316L		
Other	Glass, Ni, NiFe,	Stainless steel 302S26	Glass, Ni, NiFe, PTFE

\* Refer to [Figure: Item description matrix](#) for characteristics.

### 3.3 Performance data

Refer to [Figure: Item description matrix](#) for characteristics.

*Table 4 Performance data*

Characteristic	Pressure range	Typical accuracy
Filament		
M or MP	100 mbar to 1000 mbar	±50% reading
	$1 \times 10^{-3}$ mbar to 100 mbar	±15% reading
	$5 \times 10^{-4}$ mbar to $1 \times 10^{-3}$ mbar	±50% reading

Characteristic	Pressure range	Typical accuracy
Filament		
LC	10 mbar to 100 mbar	±50% reading
	$1 \times 10^{-3}$ mbar to 10 mbar	±15% reading
	$1 \times 10^{-4}$ mbar to $1 \times 10^{-3}$ mbar	±50% reading

Table 5 APG200 with standard voltage output

Characteristic		Pressure range
Voltage output	Filament	
X (Log-linear with pressure)	M or MP	$5 \times 10^{-4}$ mbar to 1000 mbar
X (Log-linear with pressure)	LC	$1 \times 10^{-4}$ mbar to 1000 mbar
[blank] (Non-linear)	M or MP	$1 \times 10^{-3}$ mbar to 1000 mbar
[blank] (Non-linear)	LC	$1 \times 10^{-4}$ mbar to 1000 mbar

Table 6 APG200 with matched voltage output

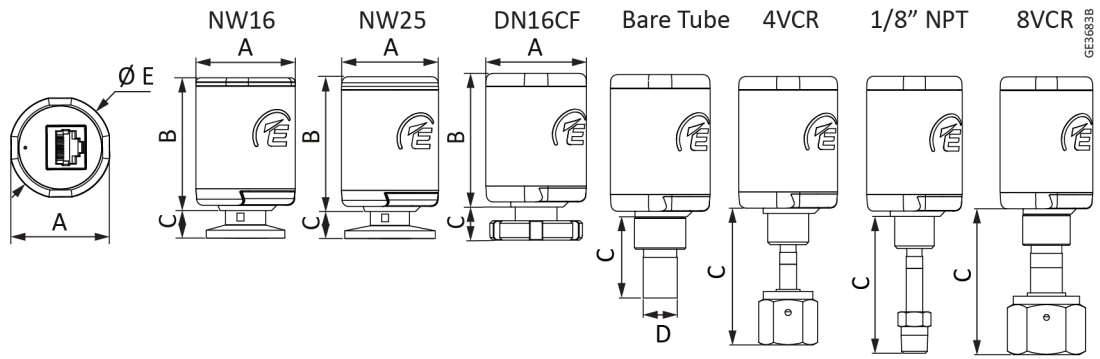
Characteristic		Pressure range
Voltage output	Filament	
O or G (Log-linear with pressure)	M or MP or LC	$5 \times 10^{-4}$ mbar to 1000 mbar
Q (Log-linear with pressure)	M or MP	$5 \times 10^{-4}$ mbar to 1000 mbar
Q (Log-linear with pressure)	LC	$1 \times 10^{-4}$ mbar to 1000 mbar

### 3.4 Mechanical data

Table 7 Mechanical data

Characteristic	Value	Units
Dimensions	Refer to <a href="#">Figure: Dimensions (mm)</a>	mm
Enclosure rating	IP40	-
Mass	≤ 200	g
Internal volume of tube		
Flange	NW16	3.3
	NW25	3.3
	1/8" NPT	3.8
	4VCR	3.6
	8VCR	5.5
	Bare tube	4.8
	DN16CF	3.3
		cm <sup>3</sup>

Figure 4 Dimensions (mm)



Characteristics	Dimension (mm)				
Filament/Pressure range	A	B	C	D	E
NW16	37	52	11	-	38
NW25	37	52	11	40	
DN16CF	37	52	13	-	
Bare Tube	37	52	30	12.7	
4VCR	37	52	38	-	
1/8" NPT	37	52	51	-	
8VCR	37	52	39	-	

### 3.5 Electrical data

Table 8 Electrical data

Parameter	Data
Electrical supply voltage	<ul style="list-style-type: none"> <li>▪ 15 to 48 V d.c. nominal <math>\pm</math> 10%</li> <li>▪ Limited-energy circuit/source in accordance with IEC 61010-1</li> </ul>
Maximum power consumption	1.5 W
Maximum inrush current	150 mA
Electrical connector	9 way D-sub male RJ45 8-way
Minimum load impedance	10 k $\Omega$
Maximum output current	1 mA

**Note:**

National Electrical Code (NEC) Class 2 or Limited Power Source (LPS) are also accepted.

### 3.5.1 ID resistor

*Table 9 ID resistor*

Characteristic		ID resistor
Voltage output	Filament/Pressure range	
APG200 with standard voltage output		
X (Log-linear with pressure)	M or MP	36 k $\Omega$
	LC	43 k $\Omega$
[blank] (Non-linear)	M or MP	27 k $\Omega$
	LC	33 k $\Omega$
APG200 with matched voltage output		
O, G, Q (Log-linear with pressure)	M, MP or LC	27 k $\Omega$

### 3.5.2 Pressure output signal

*Table 10 Pressure output signal*

Characteristic		Pressure measurement output signal	Error voltages	
Voltage output	Filament		Error	Voltage
APG200 with standard voltage output				
X (Log-linear with pressure)	LC	V=1.9 - 9.1	Filament	9.5 V
			Calibration	9.6 V
	M or MP	V=1.9 - 9.1	Filament	9.5 V
			Calibration	9.6 V
[blank] (Non-linear)	LC, M or MP	V=2.0 - 10.0	All errors	0.1 V
APG200 with matched voltage output				
O (Log-linear with pressure)	LC, M or MP	V=2.2 - 8.5	All errors	0.5 V
G (Log-linear with pressure)	LC, M or MP	V=1.9 - 10.0		0.1 V
Q (Log-linear with pressure)	LC	V=1.875 - 8.875		9.5 V
	M or MP	V=2.573 - 8.875		

### 3.5.3 Setpoint

**Table 11 Setpoint**

Characteristic		Setpoint	
Voltage output	Filament	Adjustment range	Hysteresis
[blank] (Log-linear with pressure)	LC, M or MP	V=1.8 - 9.2	0.5 V
O (Log-linear with pressure)	LC, M or MP	V=2.0 - 8.7	10% pressure
G (Log-linear with pressure)	LC, M or MP	V=0.8 - 10.2	
Q (Log-linear with pressure)	LC, M or MP	V=1.7 - 9.0	

**Table 12 Transistor setpoint variants ([blank] characteristic)**

Parameter	Data
Open collector transistor	1 (Quantity)
Maximum external load rating	48 V d.c. maximum, 100 mA
Back EMF suppression diode*	minimum surge rating 1 A minimum reverse voltage rating 100 V

\* Recommended when external DC relay is connected, refer to [Figure: 9 way D-sub connector with setpoint transistor](#) and [Figure: RJ45 connector with dual relays](#).

**Table 13 Solid state relay variants ("S" characteristic)**

Parameter	Data
Solid State relay	2 (Quantity)
Form	Single Pole Single Throw (SPST), Normally Open (N.O.)
Rating	48 V d.c. maximum, 500 mA
Relay on series resistance	Typical 0.2 $\Omega$ , maximum 0.3 $\Omega$



## 4. Installation

### 4.1 Unpack and inspect

1. Remove the packing materials and protective covers.
2. Examine the gauge.
3. If the gauge is damaged, tell the supplier and carrier in writing in three days. Give:
  - item number of the gauge
  - order number
  - supplier invoice number of the gauge.
4. Keep the packing materials for inspection.
5. Do not use the product if it is damaged.
6. If the system is not used immediately, put the protective cover and packing materials on the gauge.
7. Store the gauge in applicable conditions. Refer to [Table: Operating and storage conditions](#).

Check that your package contains the following items:

**Table 14 Checklist of items**

Quantity	Description	Check
1	APG200 gauge	<input type="checkbox"/>
1	Test report	<input type="checkbox"/>
1	Adjustment tool	<input type="checkbox"/>
1	Instruction manual	<input type="checkbox"/>

### 4.2 Install the gauge



#### **WARNING: HIGH PRESSURE**

Risk of damage to equipment. Use a co-seal or trapped O-ring carrier to connect the gauge to a vacuum system. If the pressure is more than the atmospheric pressure, the standard centring rings are not applicable.



#### **WARNING: CRITICAL APPLICATION**

Risk of damage to equipment. Do not use the gauge for safety critical applications. The gauge is not intended to be fail-safe.

To install the gauge, do the procedure as follows:

1. You can install the gauge in any direction.
2. In factory, the gauge is installed vertically and calibrated for nitrogen.
3. For the correct pressure indication at the direction of installed gauge, calibrate the gauge again at atmospheric pressure.

4. Mount the gauge tube in vertical direction to minimise the build up of process particulates and condensable vapours within the gauge.
5. For precision, we recommend that the atmosphere and vacuum adjustment must be done before use. Refer to [Maintenance](#) on page 36.

## 4.3 Connect the gauge

### 4.3.1 Connect to the vacuum system

To connect the gauge to the vacuum system:

- Use an O-ring or a centring-ring or a co-seal to connect the gauge with NW16 or NW25 flange to a similar flange on the vacuum system. The gauge is not compatible with centering ring adaptors.
- Use a new copper gasket to connect the gauge with a DN16CF flange and a new face seal metal gasket to connect the gauge with a 8VCR or 4VCR flange to a similar flange on the vacuum system.
- Apply 2 to 3 turns of 6 mm or 1/4" wide PTFE tape to a gauge with an 1/8" NPT flange. Begin at the start of the thread and wrap in the direction of the threads to make sure that the seal is leak tight.
- Make sure that the vacuum system has a correct earth (ground) connection.
- Connect the tube of the gauge to the vacuum system.

### 4.3.2 Connect to the electrical equipment



#### CAUTION: GAUGE MALFUNCTION

**Risk of damage to equipment. Do not make connections to the gauge identification pin. Failure to do so can cause the gauge to malfunction.**

Refer to [Figure: Recommended electrical connections](#) for schematic diagram of the electrical connections to the gauge. Use the pins on the electrical connector as shown in [Table: Pins on the APG200 electrical connector](#).

Refer to [Technical data](#) on page 12 for more specifications.

**Figure 5** Electrical connectors

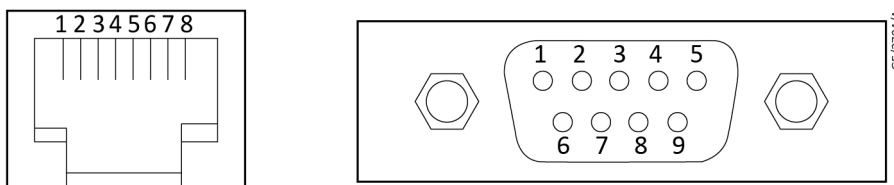


Table 15 Pins on the gauge electrical connector

Connector	9 way D-sub male		RJ45 8-way	
Characteristic	[blank] Setpoint transistor	[S] Dual relays	[blank] Setpoint transistor	[S] Dual relays
Pin	Refer to <i>Figure: Electrical connectors</i>			
1	Setpoint output signal	Relay 1 N.O.	Electrical supply positive	
2	ID resistor		Electrical supply ground (0 V)	
3	Electrical supply positive		Pressure measurement output signal	
4	Electrical supply ground (0 V)		ID resistor	
5	Pressure measurement output signal		Signal ground	
6	Not connected	Relay 1 common	Setpoint output signal	Relay 1 N.O.
7	Not connected	Relay 2 common	Remote calibration input	Relay 2 N.O.
8	Signal ground		Not connected	Relay common
9	Remote calibration input	Relay 2 N.O.	-	-

### Recommended electrical connections

- Do not connect the electrical supply ground to the signal ground. If you connect the electrical supply ground to the signal ground, the gauge output signal will not be accurate.
- When you use the gauge in an electrically noisy environment, make sure that your measuring equipment is immune to the interference.

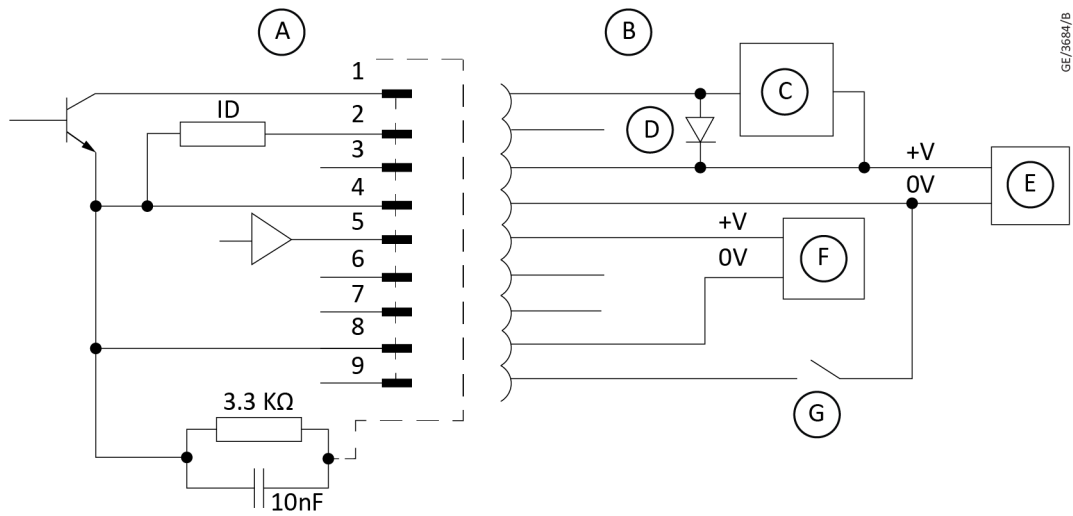
For setpoint transistor variants only:

- The setpoint output is an active low open-collector transistor applicable to operate a DC relay or control logic. If you connect an external relay, use a suppression diode to protect the gauge from transient voltages generated when the relay is set to off.
- Setpoint transistor variants includes a remote calibration feature. Connect the power supply ground (0 V) to the remote calibration input momentarily (> 50 ms) to automatically adjust the atmosphere or vacuum reading. Refer to [Maintenance](#) on page 36 for the procedure.

 **Note:**

*All the controllers supplied by us have sufficient immunity.*

**Figure 6** 9 way D-sub connector with setpoint transistor

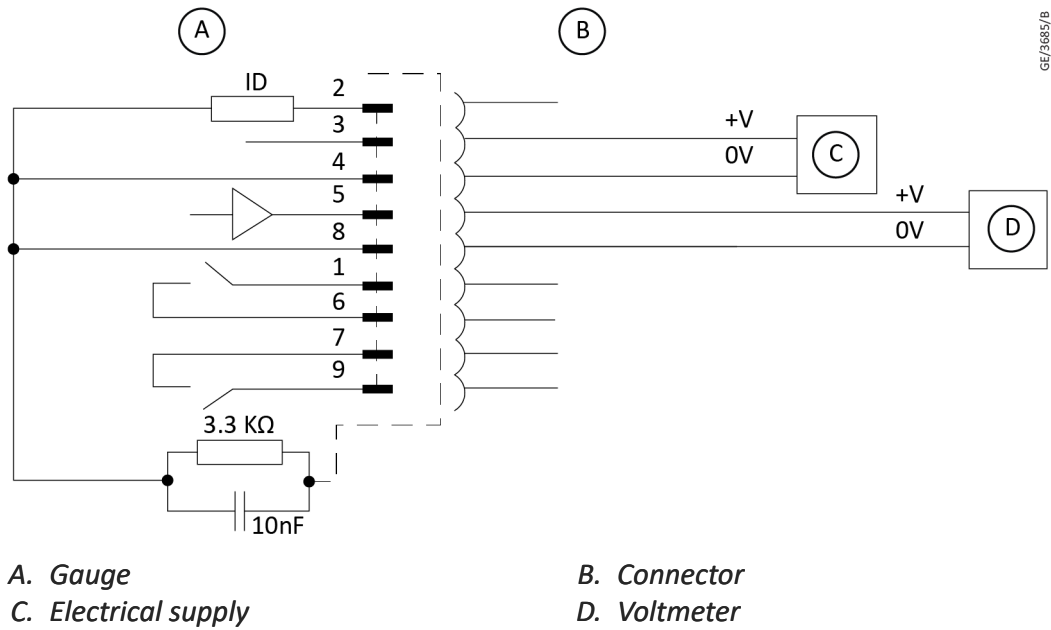


- A. Gauge
- C. DC relay (optional)
- E. Electrical supply
- G. Grounding switch (optional)

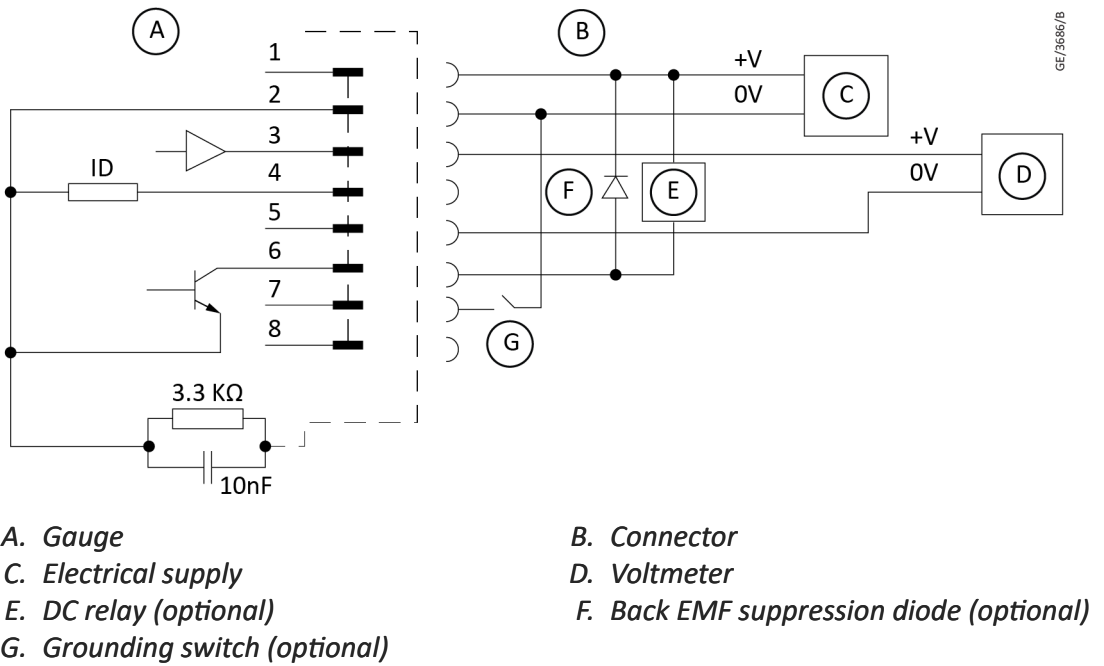
- B. Connector
- D. Back EMF suppression diode (optional)
- F. Voltmeter

Refer to [Table: Pins on the APG100 electrical connector](#) for additional information concerning the pins.

**Figure 7** 9 way D-sub connector with dual relays

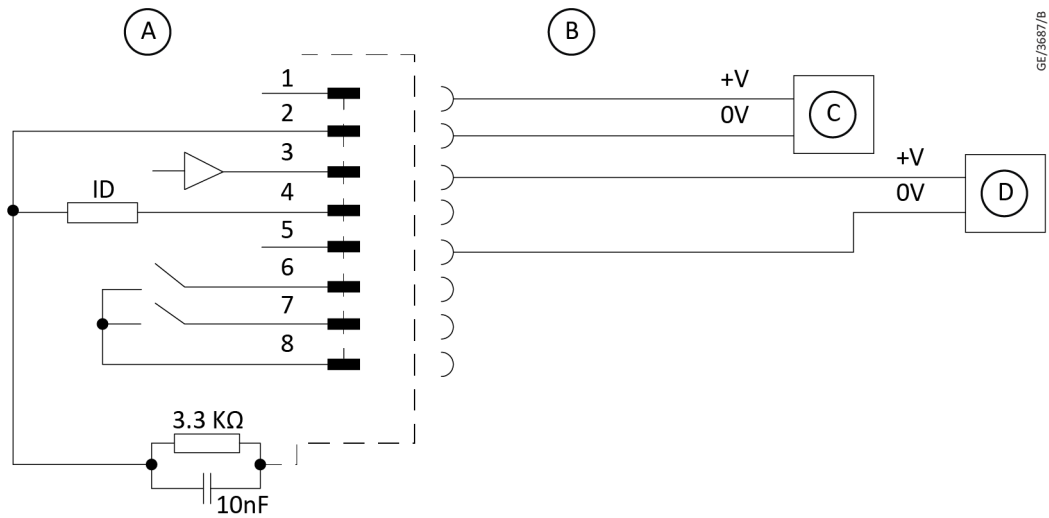


**Figure 8** RJ45 connector with setpoint transistor



Refer to [Table: Pins on the APG100 electrical connector](#) for additional information concerning the pins.

**Figure 9** RJ45 connector with dual relays



- A. Gauge
- B. Connector
- C. Electrical supply
- D. Voltmeter

Refer to [Table: Pins on the APG100 electrical connector](#) for additional information concerning the pins.

### 4.3.3 Maximum cable length

The maximum cable length is dependent on the conductor cross-section and the supply voltage used.

**Table 16** Maximum cable length

Electrical supply voltage	Maximum cable length (24 AWG)
15 V	100 m
48 V	1000 m

The common mode signal voltage (that is, the voltage between the signal common and supply common) can be significant with long cables due to the voltage drop in the cable. For accurate pressure measurements, do not connect the electrical supply ground to signal ground. Both ground connections are linked within the gauge.

## 5. Operation

### WARNING: HIGH FILAMENT TEMPERATURE



Risk of injury or damage to equipment. Do not use the gauge to measure the pressure of explosive or flammable gases or mixtures. The gauge has a heated filament which operates approximately at 100 °C. The temperature of the filament can be higher in fault conditions.

### WARNING: OVER-PRESSURISE



Risk of injury or damage to equipment. When you measure the pressure of gases of high molecular weight, the pressure indicated can be below the true pressure. Make sure that the gauge is not over-pressurised when using heavy gases.

### 5.1 LED indicator

When the gauge is connected to a power supply the LED indicator will illuminate and flash red for approximately 5 seconds while the gauge is initialising. The LED indicator indicates the gauge status:

- green if the gauge is operating normally
- red if an error is detected. Refer to [Fault finding](#) on page 39.

#### Normal operation

During normal operation, the LED indicator pulses to provide an approximate indication of the measured pressure.

Pressure band	LED pattern		
	Colour	Change rate	
		High intensity (s)	Low intensity (s)
Pressure ≤ 1 mbar	Green	Continuous	n/a
1 mbar < Pressure ≤ 50 mbar		0.75	0.75
Pressure > 50 mbar		1.5	1.5

The pulsing operation (low intensity/high intensity) is switched on by default but can be disabled (refer to [Pulsed LED indicator on/off](#) on page 34). If pulsing is disabled, the LED will be green continuously during normal operation.

#### Note:

*The pulsing function enabled/disabled is unaffected by power cycling the gauge.*

#### Error indication

If an error occurs within the gauge, the LED indicator will illuminate red and flash. Refer to [Fault finding](#) on page 39.

## 5.2 Pressure measurement

It is possible to read the pressure from the gauge using a controller or by reading the gauge voltage with a voltmeter and converting the indicated voltage to pressure.

If the gauge has a standard voltage output characteristic, if connected to our controller then the display will indicate the measured pressure. Refer to [Pressure output signal](#) on page 15.

 **Note:**

*The gauge models with matched voltage outputs are not compatible with our controllers. The gauge may not be recognised or the pressure output may not be correct.*

### 5.2.1 APG200 with Log linear with pressure output

If the gauge is connected to a voltmeter, convert the voltage (V) to pressure (P) according to the formulae in the following table:

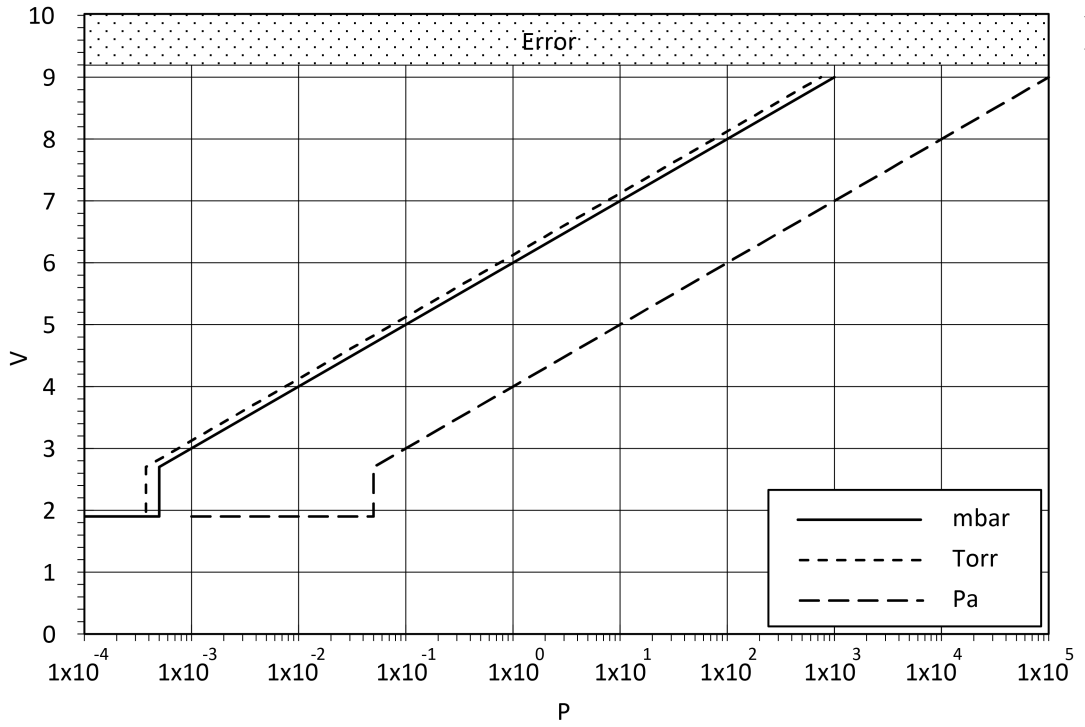
Characteristics		Formula: $10^{((V-a)/b)}$				
Voltage output	Filament/pressure range		P (mbar)	P (Torr)	P (Pascals)	Range of formula
X (Log-linear with pressure)	LC	a	6.000	6.125	4.000	V=2.0 - 9.0
		b	1.000	1.000	1.000	
X (Log-linear with pressure)	M or MP	a	6.000	6.125	4.000	V=2.7 - 9.0
		b	1.000	1.000	1.000	
O (Log-linear with pressure)	LC, M or MP	a	5.500	5.625	3.500	V=2.2 - 8.5
		b	1.000	1.000	1.000	
G (Log-linear with pressure)	LC, M or MP	a	6.143	6.304	3.572	V=1.9 - 10
		b	1.286	1.286	1.286	
Q (Log-linear with pressure)	LC, M or MP	a	5.875	6.000	3.875	V=1.875 - 8.875
		b	1.000	1.000	1.000	
		a	5.875	6.000	3.875	V=2.573 - 8.875
		b	1.000	1.000	1.000	

### 5.2.2 Voltage to pressure conversion for APG200

The following figures shows variation in pressure with voltage for the different voltage output characteristics of APG200.

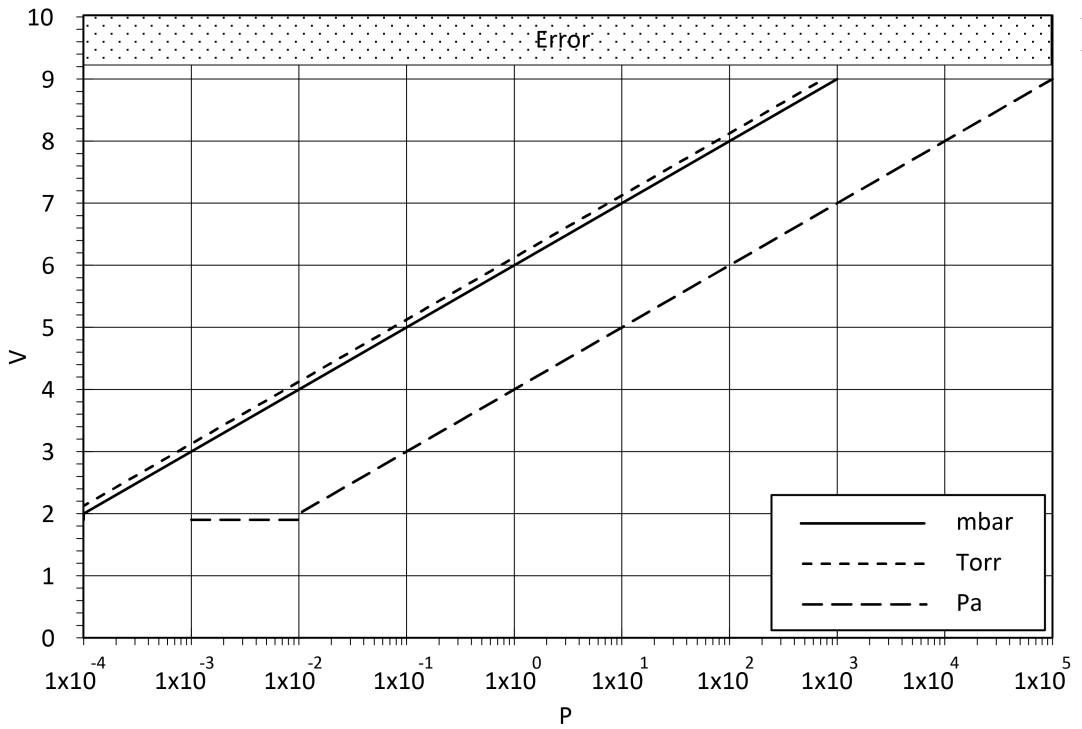


Figure 10 XM, XMP



GE/3696/B

Figure 11 XLC



GE/3694/B

Figure 12 "O" output curves

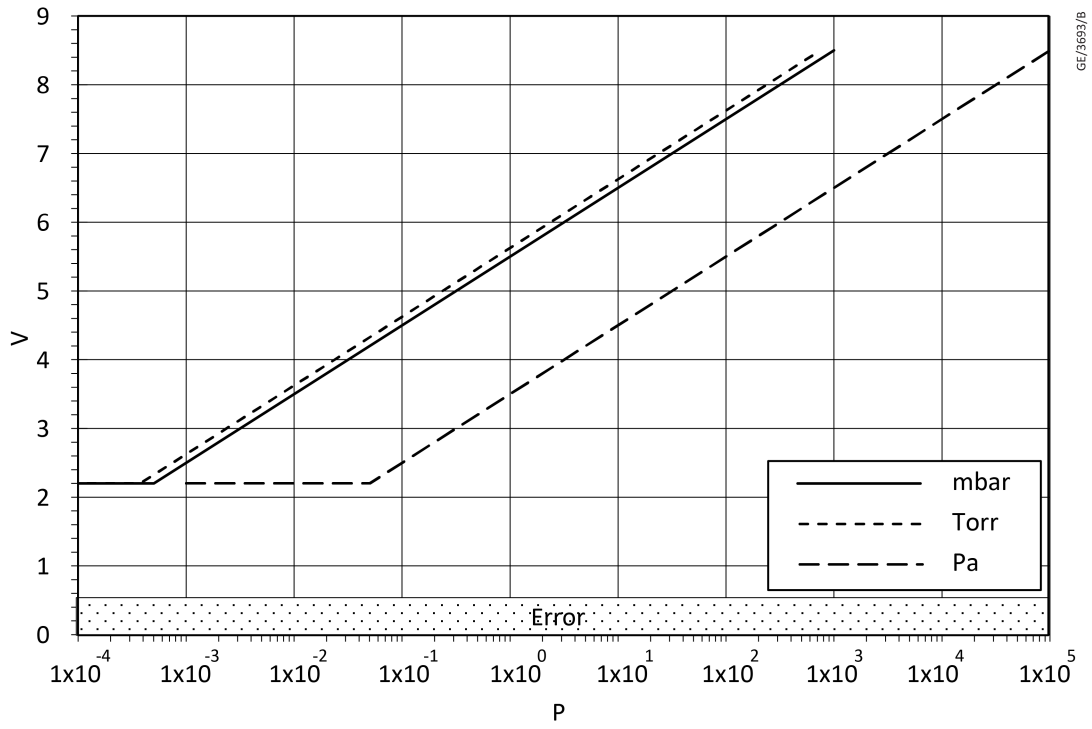


Figure 13 "G" output curves

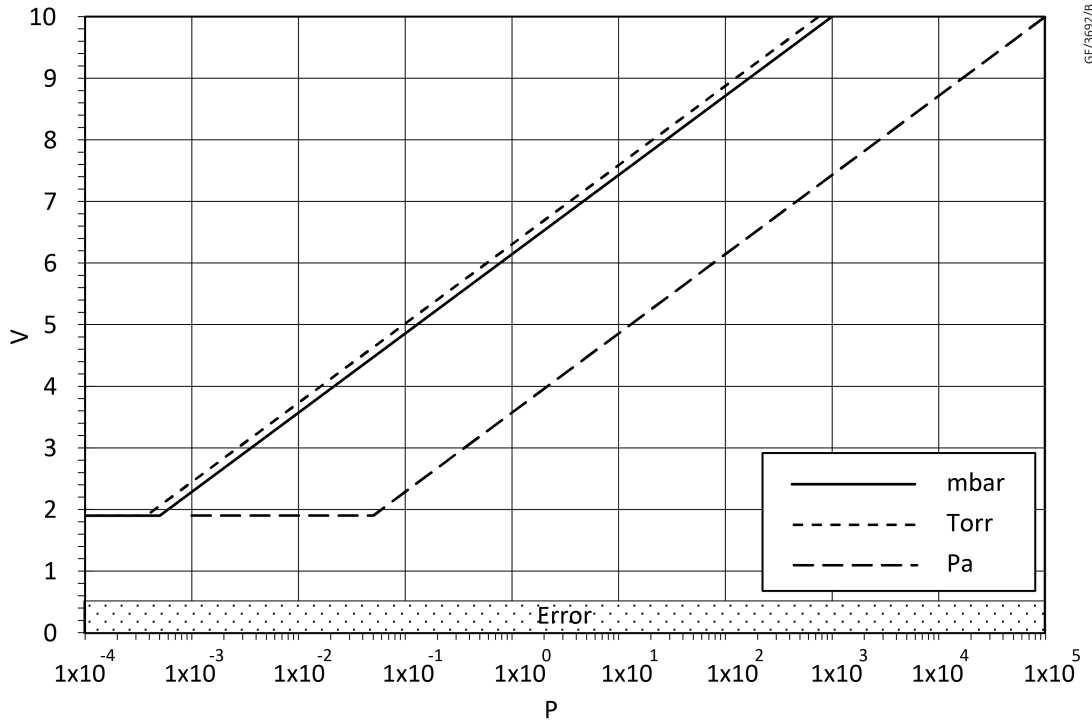


Figure 14 Q, LC variant

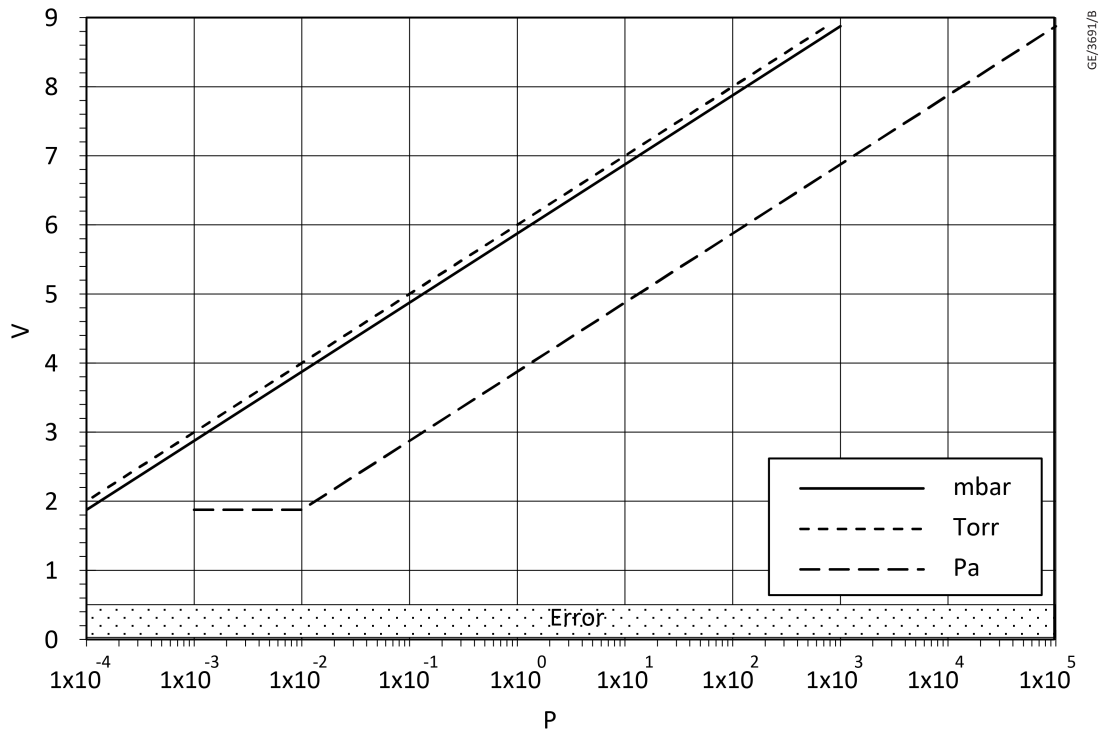
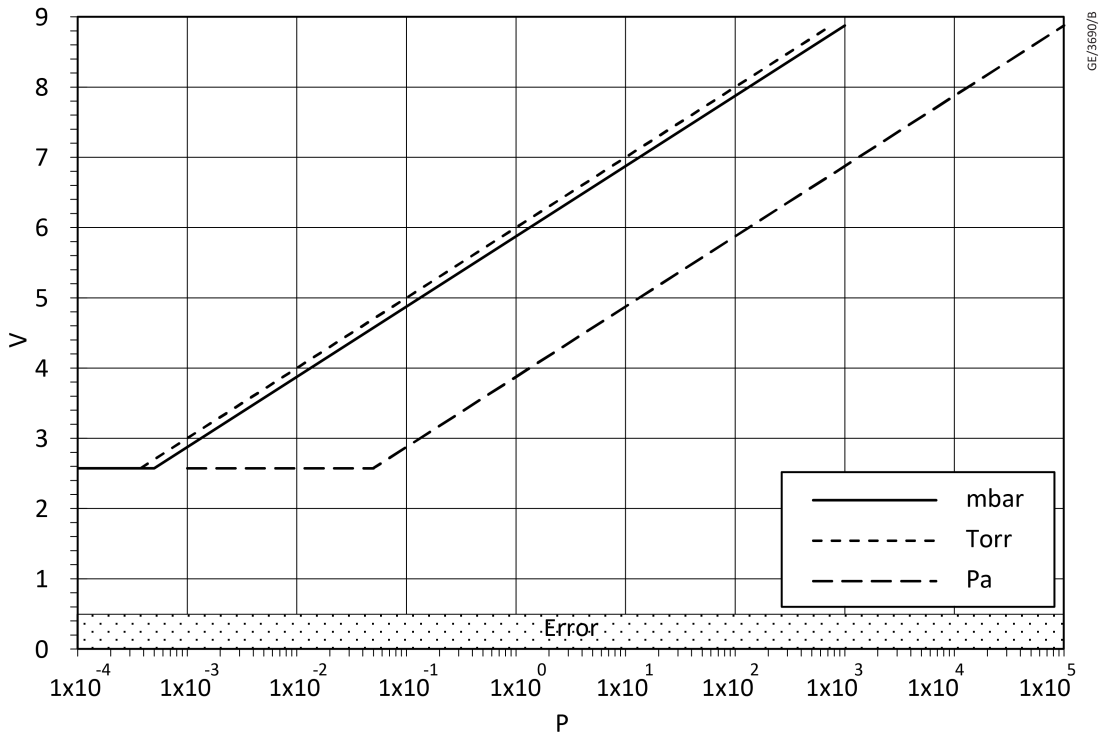


Figure 15 Q, M, MP variants



### 5.2.3 APG200 with non-linear pressure output

If the gauge is connected to a voltmeter, convert the voltage (V) to pressure (P) according to the following tables.

*Table 17 APG200 with non-linear pressure output*

Voltage	Pressure	
	M, MP (mbar)	LC (mbar)
2	$< 1 \times 10^{-4}$	$< 1 \times 10^{-5}$
2.05	$2.31 \times 10^{-4}$	$8.26 \times 10^{-5}$
2.1	$6.21 \times 10^{-4}$	$2.27 \times 10^{-4}$
2.2	$1.36 \times 10^{-3}$	$5 \times 10^{-4}$
2.4	$2.97 \times 10^{-3}$	$1.08 \times 10^{-3}$
2.6	$4.61 \times 10^{-3}$	$1.68 \times 10^{-3}$
2.8	$6.51 \times 10^{-3}$	$2.60 \times 10^{-3}$
3.0	$1.02 \times 10^{-2}$	$3.84 \times 10^{-3}$
3.2	$1.47 \times 10^{-2}$	$5.15 \times 10^{-3}$
3.4	$1.91 \times 10^{-2}$	$6.87 \times 10^{-3}$
3.6	$2.95 \times 10^{-2}$	$1.05 \times 10^{-2}$
3.8	$4.16 \times 10^{-2}$	$1.56 \times 10^{-2}$
4.0	$5.61 \times 10^{-2}$	$2.10 \times 10^{-2}$
4.2	$7.20 \times 10^{-2}$	$2.77 \times 10^{-2}$
4.4	$8.94 \times 10^{-2}$	$3.45 \times 10^{-2}$
4.6	$1.13 \times 10^{-1}$	$4.16 \times 10^{-2}$
4.8	$1.45 \times 10^{-1}$	$5.04 \times 10^{-2}$
5.0	$1.76 \times 10^{-1}$	$5.92 \times 10^{-2}$
5.2	$2.22 \times 10^{-1}$	$8.74 \times 10^{-2}$
5.4	$3.16 \times 10^{-1}$	$1.27 \times 10^{-1}$
5.6	$4.13 \times 10^{-1}$	$1.71 \times 10^{-1}$
5.8	$5.40 \times 10^{-1}$	$2.23 \times 10^{-1}$
6.0	$6.82 \times 10^{-1}$	$2.90 \times 10^{-1}$
6.2	$8.41 \times 10^{-1}$	$3.57 \times 10^{-1}$
6.4	1.06	$4.35 \times 10^{-1}$
6.6	1.33	$5.33 \times 10^{-1}$
6.8	1.60	$6.40 \times 10^{-1}$
7.0	1.87	$7.67 \times 10^{-1}$
7.2	2.26	$9.23 \times 10^{-1}$
7.4	2.75	1.14
7.6	3.24	1.40
7.8	3.73	1.66
8.0	4.39	1.92

Voltage (V)	Pressure	
	M, MP (mbar)	LC (mbar)
8.2	5.29	2.38
8.4	6.27	2.95
8.6	7.63	3.51
8.8	9.39	4.17
9.0	$1.27 \times 10^1$	5.40
9.2	$1.67 \times 10^1$	7.06
9.4	$2.24 \times 10^1$	9.69
9.5	$2.88 \times 10^1$	$1.29 \times 10^1$
9.6	$3.53 \times 10^1$	$1.66 \times 10^1$
9.7	$4.48 \times 10^1$	$2.07 \times 10^1$
9.8	$6.65 \times 10^1$	$3.39 \times 10^1$
9.9	$1.41 \times 10^2$	$6.32 \times 10^1$
9.95	$6.16 \times 10^2$	$1.44 \times 10^2$
10	$1.00 \times 10^3$	$1.00 \times 10^3$

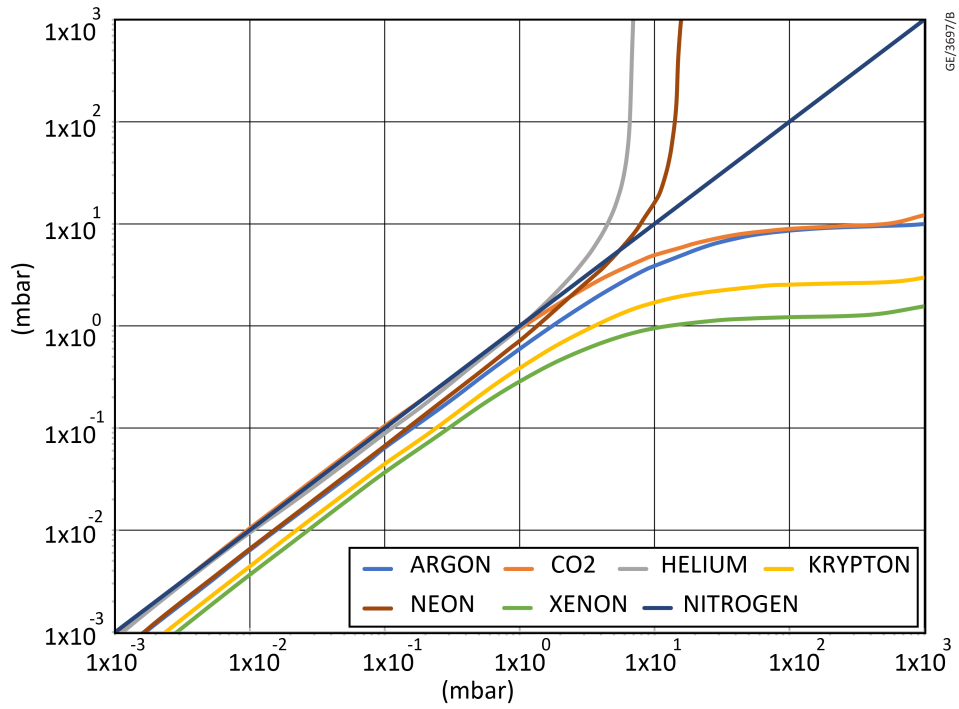
### 5.3 Gas dependency

The gauge is calibrated for the use in nitrogen and will read correctly with dry air, oxygen and carbon monoxide. For the other gases a conversion is necessary to get the correct pressure reading. Refer to [Table: Gas calibration factors below 1 mbar](#) for the conversion factors of the gases of pressures less than 1 mbar.

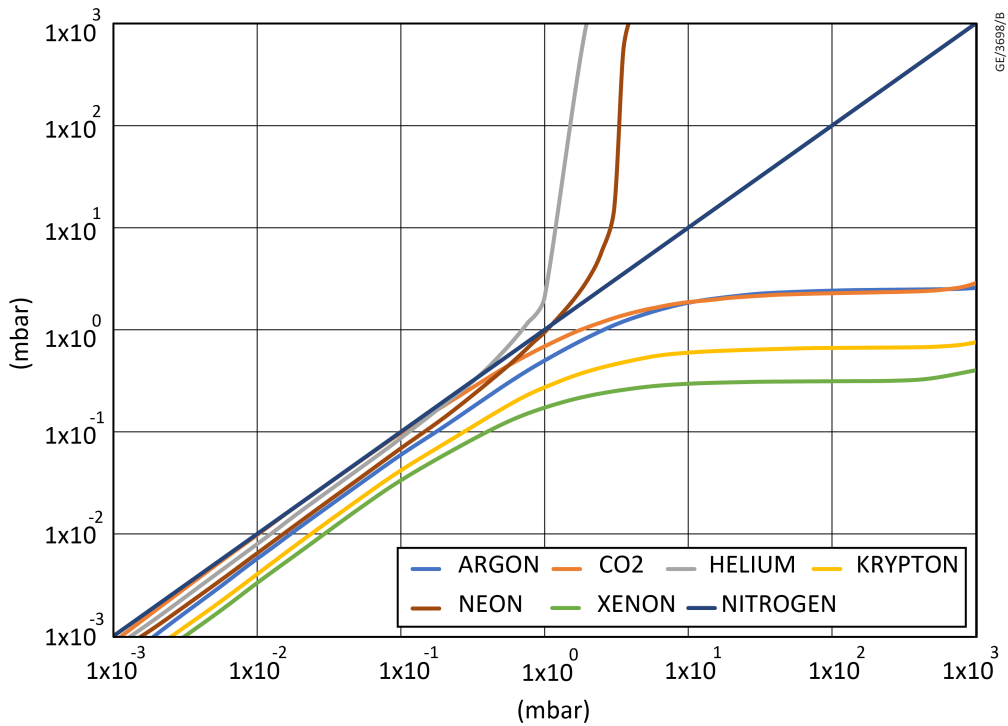
The conversion formula is:

True pressure = Gas Calibration Factor (GCF) x indicated pressure.

**Figure 16** Gas dependency of APG200 with M, MP filament/pressure characteristic



**Figure 17** Gas dependency of APG200 with LC filament/pressure characteristic



**Note:**

*X-axis - True pressure*

*Y-axis - Indicated pressure*

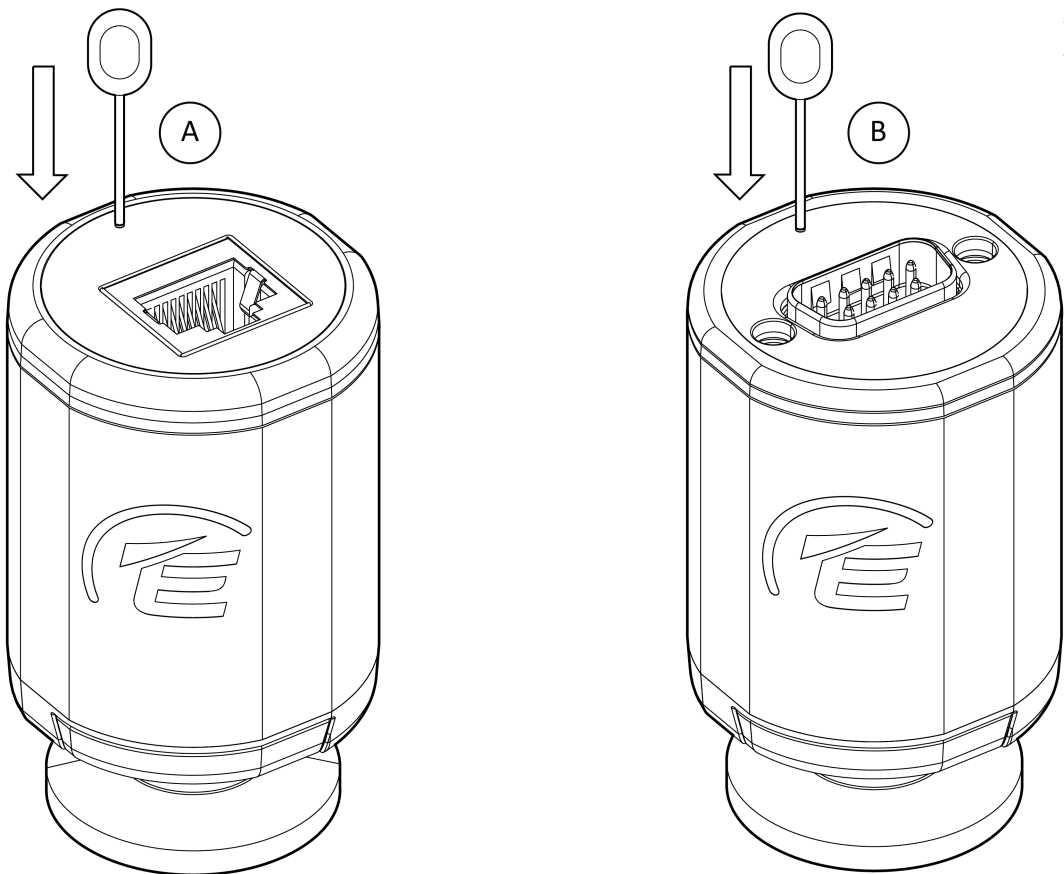
*Table 18 Gas calibration factors below 1 mbar*

<b>Gas</b>	<b>Gas Calibration Factors (GCF)</b>
He	1.1
Ne	1.5
N <sub>2</sub>	1.0
Ar	1.7
CO <sub>2</sub>	1.0
Kr	2.5
Xe	3.0

## 5.4 Advanced functions

Access to additional functions can be achieved through the pressing of a multi-function button located on the top of the gauge. The multi-function button can be used during the operation and maintenance of the gauge. A tool for the purpose of adjustment is provided with the product.

Figure 18 Adjustment of APG200



GE/3699/A

- Press the button and the LED indicator changes colour and begins flashing. If the button remains depressed, the colour of the flashing LED indicator changes every 2 seconds to allow the selection of different functions.
- Release the button when the desired function is reached.
- When the button is released the LED indicator stops flashing and remains permanently lit. The colour of the LED indicator signifies the selected function.
- Press the button momentarily to confirm the selection. If not pressed within 5 seconds, the gauge reverts to normal operation.

Detailed information on how to select the various functions available can be found in [Appendix - Multi-function button operation](#) on page 45.

### 5.4.1 Setpoint adjustment



#### CAUTION: SETPOINT MALFUNCTION

**Risk of damage to equipment. When you push the 'S/P' button, the gauge output will change. Do not push the 'S/P' button to adjust the setpoint if the change in output could cause a malfunction of your system.**

Refer to [Appendix - Multi-function button operation](#) on page 45, select the setpoint adjustment function using the multi-function push button. Do the procedure that follows for setpoint adjustment:



 **Note:**

*For the gauge models with a single open collector transistor setpoint output, “Setpoint 2” function is omitted when the LED indicator cycles through the available functions.*

1. When the setpoint adjustment function is selected (LED indicator permanently illuminates purple or blue), press momentarily to confirm the selection and release the multi-function push-button.
  - The pressure measurement output signal will change to indicate the setpoint threshold.
  - The LED indicator will blink to indicate the commencement of setpoint adjustment.

 **Note:**

*If the multi-function button is not released within 5 seconds, the gauge will skip to the next step in the process.*

2. To adjust the threshold, press and hold the button.
  - The setpoint threshold will increase steadily. Release the button when the desired threshold is reached
  - To make finer adjustments, release the button before the desired threshold is reached and then make small adjustments by pressing the button several times. The output will step up in increments of approximately 10 mV.
  - When the setpoint threshold reaches the upper limit of the adjustment range (refer to [Setpoint](#) on page 16) the setpoint will step to the lower limit of the range and starts increasing again
  - The LED indicator will blink to signify the end of the adjustment process and return to normal operation after the button has been released for 5 seconds.
3. When the measured pressure is less than the setpoint pressure the relay closes (low impedance) or the transistor output changes to ON.
4. When the pressure rises above the setpoint threshold by the hysteresis value, the relay opens (high impedance) or the transistor output changes to OFF. Hysteresis values depend on the model of the gauge. Refer to [Setpoint](#) on page 16 for hysteresis values.
5. For gauge with a log linear voltage output, the setpoint can be adjusted to values outside the range of the pressure measurement output signal.
  - If the setpoint is set to a value lower than the range of the pressure measurement output signal, the setpoint will remain permanently off.
  - If the setpoint is set to a value greater than the range of the pressure measurement output signal, the setpoint will be permanently on as long as the gauge is operating normally.

 **Note:**

*- By ensuring the setpoint is set to permanently ON, the setpoint can be used to indicate that the gauge is operating correctly.*

*- For the gauge models with a non-linear voltage output, the setpoint cannot be switched permanently on or permanently off.*

## Pulsed LED indicator on/off

Refer to [Appendix - Multi-function button operation](#) on page 45, select the pulsed LED on/off function using the multi-function push-button.

When the function is selected, the LED indicator indicates pink and remains permanently illuminated. Confirm the selection by momentarily pressing and releasing the multi-function push-button. The LED indicator will flash rapidly for 3 seconds to indicate that the operation is complete before it reverts to illuminating green with the pulsed indicator changed.

## Restore user selectable parameters to default/previous values

It is possible to restore the setpoint values and the LED indicator pulsing state to default values. In the event of making an unintentional change to the LED indicator or setpoint values, it is also possible to rectify the error by restoring the previous values/state.

### LED/setpoint default

The following procedure restores the LED indicator to pulsing and the setpoints to their default values:

 **Note:**

*The LED indicator is set to pulsing by default and the setpoints are set to their minimum values.*

1. Select the LED/setpoint default function using the multi-function push-button (LED indicator permanently indicating white).
2. Confirm the selection by momentarily pressing and releasing the multi-function push-button.
3. The LED indicator will flash white to indicate the operation is being performed
4. After 3 seconds, the LED indicator stops flashing and the LED indicator pulsing and setpoint(s) are restored to factory values.

### Restore previous LED/setpoint values

The following procedure restores the LED indicator pulsing to its previous state and the setpoints to their previous values:

1. Select the “restore previous LED/setpoint values” function using the multi-function push-button (LED indicator permanently indicating white).
2. Confirm the selection by momentarily pressing and releasing the multi-function push-button.
3. The LED indicator will rapidly flash white to indicate the operation is being performed
4. After 3 seconds, the LED indicator stops flashing and the LED indicator pulsing and setpoint(s) are restored to their previous values.

## 5.5 Operation errors

If a gauge error occurs during operation, then the LED indicator illuminates red signifying an error.

If the multi-function button being held down for more than 1 minute, the LED indicator turns solid red. The pressure measurement output signal and setpoint are unaffected. When the button is released, the LED indicator turns green signifying normal operation.

In the case of filament and calibration errors, the output voltage will change to signify the error condition and will latch until the condition is rectified and the power to the gauge is cycled. The setpoint will additionally switch off in the event of calibration and filament errors. Refer to [Fault finding](#) on page 39 for details of how to remedy the situation.

**Table 19 Error indication**

LED indication			Meaning	Cause	Error voltage
Colour	Change rate				
	On (s)	Off (s)			
Red	0.25	0.25	Filament error	Filament broken; tube not fully inserted	Refer to <a href="#">Pressure output signal</a> on page 15
	0.7	0.7	Calibration error	Calibration could not be achieved	
	NA		Button error	Button stuck; held down too long	N/A

 **Note:**

*If you use our controller, a message is shown on the display.*

## 5.6 Bakeout

In some UHV applications it is desirable to bake the vacuum system components to achieve a lower base pressure. The tube of the gauge can be baked to 150 °C but the electronics housing must be removed.

- Refer to [Figure: Replace the gauge tube](#), remove the electronics housing.
- Bake the tube on your vacuum system. Do not exceed 150 °C.
- Allow the tube to cool before refitting the electronics housing.

## 6. Maintenance

### 6.1 Atmosphere and vacuum adjustment

Every gauge is adjusted before shipment however thermal conductivity gauges can drift with time or as contamination builds up on the filament. You can adjust the atmosphere and vacuum settings of the gauge to eliminate the effects of such drift. The frequency of adjustment will vary depending on the level and nature of the contamination associated with the process.

 **Note:**

*The gauge can determine whether to perform atmosphere or vacuum adjustment based on the measured pressure. If the adjustment is performed at an inappropriate pressure, the calibration error is triggered. Refer to [Fault finding](#) on page 39.*

#### 6.1.1 Atmosphere adjustment

1. Supply power to the gauge, make sure that the LED indicator is green and allow the gauge to warm up at atmospheric pressure in nitrogen or air for at least 10 minutes.
2. Refer to [Appendix - Multi-function button operation](#) on page 45, select the atmosphere or vacuum adjustment function using the multi-function push button.
3. When the atmosphere or vacuum adjustment function is selected (LED indicator is permanently indicated cyan), confirm the selection by momentarily pressing and releasing the multi-function push-button.
4. The LED indicator will flash cyan to indicate the operation is being performed.
5. After 3 seconds, the LED indicator stops flashing and the atmosphere adjustment parameters are stored in the gauge.

#### 6.1.2 Vacuum adjustment

1. Reduce the system pressure to  $1 \times 10^{-5}$  mbar (or less).
2. Operate the gauge for minimum 10 minutes.
3. Refer to [Appendix - Multi-function button operation](#) on page 45, select the “atmosphere/vacuum adjustment” function using the multi-function push button.
4. When the atmosphere/vacuum adjustment function is selected (LED indicator is permanently indicated cyan), confirm the selection by momentarily pressing and releasing the multi-function push button.
5. The LED indicator will flash cyan to indicate the operation is being performed.
6. After 3 seconds, the LED indicator stops flashing and the vacuum adjustment parameters are stored in the gauge.

#### 6.1.3 Remote adjustment - APG200 with transistor setpoint [blank] option

The gauge with transistor setpoint has a remote adjustment feature. You can perform atmosphere adjustment and vacuum adjustment through the appropriate pin on the electrical connector.

1. Refer to [Table: Pins on the APG200 electrical connector](#) depending on the electrical connector on your gauge.
2. Momentarily (> 100 msec) connect the remote calibration input to electrical supply ground and the atmosphere or vacuum adjustment will be performed.

### Adjustment for new tube

If a replacement tube is installed to the gauge it is necessary to match the characteristics of the gauge with the new tube.

1. Make sure that the gauge is at atmospheric pressure in nitrogen or air. Supply power to the gauge.
2. Make sure that the LED indicator is green refer to the [Appendix - Multi-function button operation](#) on page 45, select the tube adjustment function using the multi-function push button.
3. When the Tube adjustment function is selected (LED indicator is permanently indicated orange), confirm the selection by momentarily pressing and releasing the multi-function push button.
4. The LED indicator will flash orange to indicate the operation is being performed.
5. After 5 minutes, the LED indicator stops flashing and the tube adjustment parameters are stored in the gauge.
6. After performing adjustment for new tube, [Atmosphere adjustment](#) on page 36 and [Vacuum adjustment](#) on page 36 is recommended.

## 6.2 Replace the gauge tube

You must install a replacement tube to the gauge if:

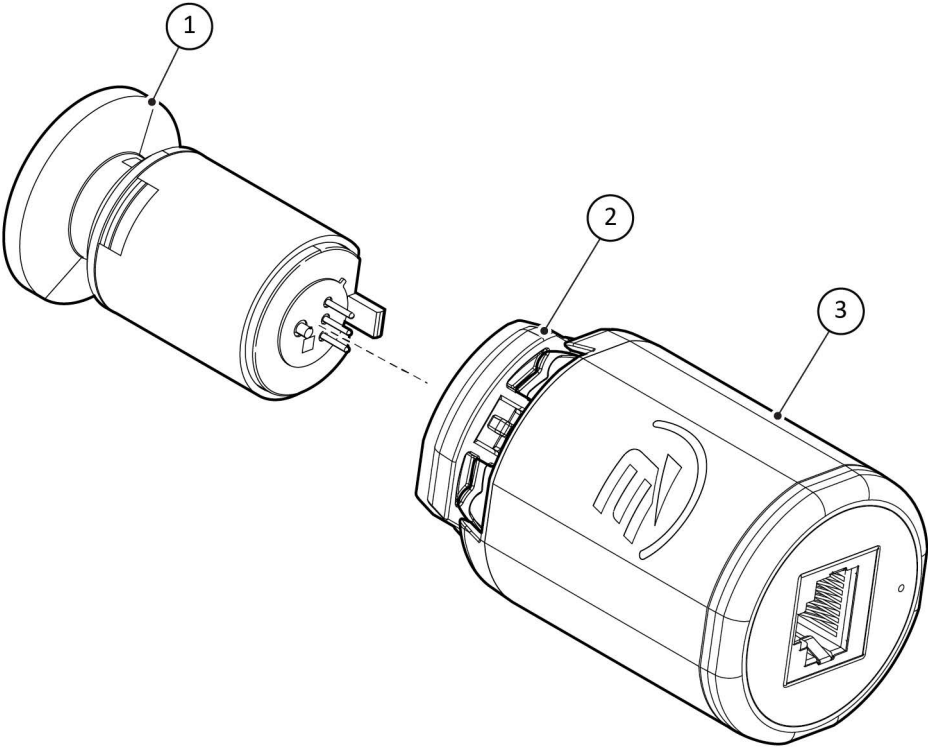
- The gauge tube is contaminated.
- The atmosphere or vacuum adjustment cannot be achieved.
- The filament is broken.

Refer to [Figure: Replace the gauge tube](#). To replace the gauge tube:

1. Unplug the electrical cable, vent the vacuum system to atmospheric pressure and remove the gauge from the vacuum system.
2. Partially pull the retaining clip from side of gauge.
3. Pull the tube from the electronics housing.
4. Install the replacement tube into electronics housing with correct alignment.
5. Install the retaining clip again.

Whenever a new tube is installed it is necessary to adjust the gauge to match the new tube. Refer to [Adjustment for new tube](#) on page 37.

**Figure 19** Replace the gauge tube



GE/A312/A

- 1. Gauge tube
- 3. Electronics housing

- 2. Retaining clip

## 7. Fault finding

*Table 20 Faults*

Fault
<a href="#">LED not lit</a> on page 39
<a href="#">Pressure reading incorrect</a> on page 39
<a href="#">Gauge shows calibration error</a> on page 39
<a href="#">Gauge shows broken filament</a> on page 40

<b>Fault</b>	<b>LED not lit</b>
Cause	Incorrect electrical supply voltage. Supply polarity reversed.
Remedy	Check the electrical supply and connections.
<b>Fault</b>	<b>Pressure reading incorrect</b>
Cause	Vacuum leak
Remedy	Do the leak check of the vacuum system.
Cause	Tube has drifted and requires adjustment
Remedy	Do the atmosphere and vacuum adjustments.
Cause	Tube is contaminated
Remedy	Replace the tube.
Cause	Gauge is measuring gas with different thermal conductivity to Nitrogen or Air.
Remedy	Refer to <a href="#">Gas dependency</a> on page 29 for correction factors.
Cause	Adjustment done at an incorrect pressure
Remedy	Repeat the adjustment but make sure that the pressure is at atmosphere or vacuum.
<b>Fault</b>	<b>Gauge shows calibration error</b>
Cause	Adjustment done at an incorrect pressure.
Remedy	Repeat the adjustment but make sure that the pressure is at atmosphere or vacuum.
Cause	Wrong type of tube is installed.
Remedy	Check that the correct type of tube is installed (M, MP, or LC).
Cause	New tube has been installed.
Remedy	Refer to <a href="#">Remote adjustment - APG200 with transistor setpoint [blank] option</a> on page 36.
Cause	Tube has drifted outside permissible limits and can not be adjusted.
Remedy	Replace the tube.

<b>Fault</b>	<b>Gauge shows broken filament</b>
<b>Cause</b>	<b>Tube is missing.</b>
Remedy	Install the tube. Remove the electrical connector and insert back.
<b>Cause</b>	<b>Wrong type of tube is installed.</b>
Remedy	Check that the correct type of tube is installed (M, MP or LC).
<b>Cause</b>	<b>Filament is broken.</b>
Remedy	Replace the tube.



## 8. Disposal

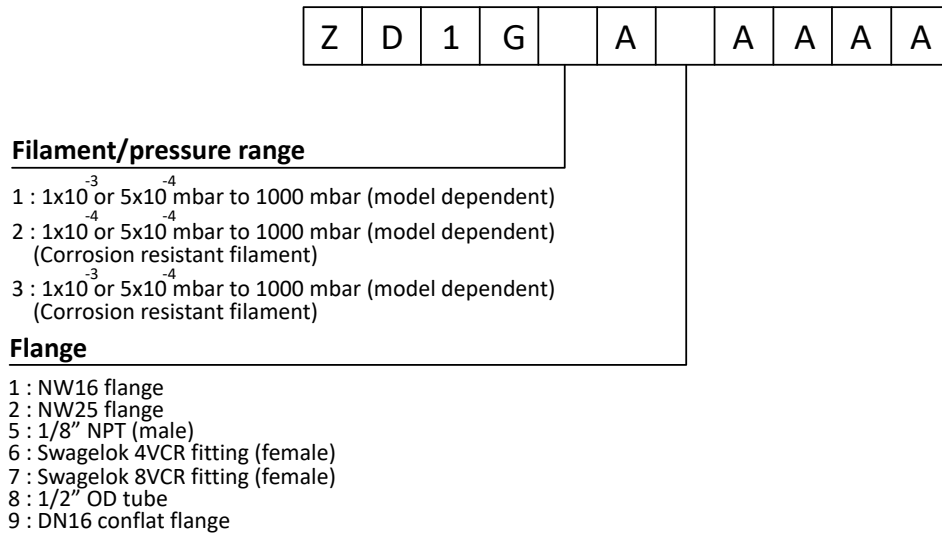
- Dispose of the gauge, components and accessories safely as per all local and national safety and environmental requirements.
- You can recycle the gauge and cables. Contact us or the supplier for more information.
- The gauge and cables are in the scope of the European Directive on Waste Electrical and Electronic Equipment, 2012/19/EU.
- For European customers we offer a recycling service for the gauge and cables at the end of the product's life.
- Be careful if the gauge is contaminated with dangerous process substances.

## 9. Spares

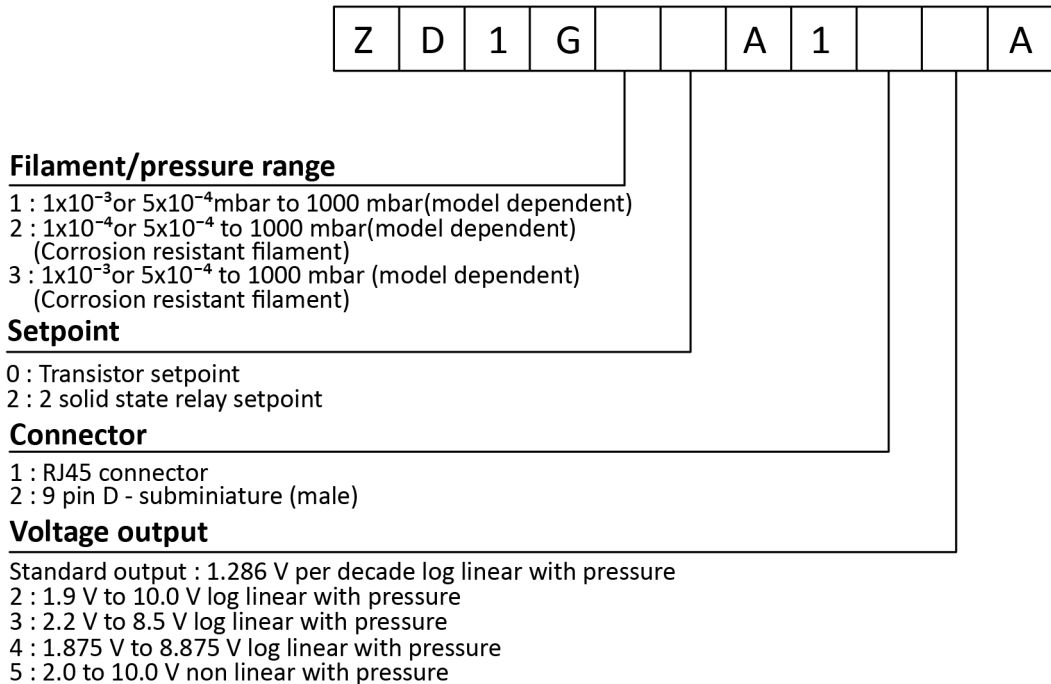
Order the spare parts and accessories from our nearest company or distributor. When you order, give:

- Model and item number of your equipment
- Serial number (if any)
- Item number and description of the part.

**Figure 20** Replacement tube spares



**Figure 21** Replacement electronics housing



## 10. Accessories

The Active gauge cables suitable for gauges installed with an RJ45 connector.

*Table 21 Active gauge cable*

<b>Cable length</b>	<b>Item number</b>
0.5 m (18 inches)	D40001005
1 m (3 feet)	D40001010
3 m (10 feet)	D40001030
5 m (15 feet)	D40001050
10 m (30 feet)	D40001100
15 m (50 feet)	D40001150
25 m (80 feet)	D40001250
50 m (150 feet)	D40001500
100 m (325 feet)	D40001999

## 11. Service

### 11.1 Return the equipment or components for service

Before you send your equipment to us for service or for any other reason, you must send us a completed Declaration of Contamination of Vacuum Equipment and Components – Form HS2. The HS2 form tells us if any substances found in the equipment are hazardous, which is important for the safety of our employees and all other people involved in the service of your equipment. The hazard information also lets us select the correct procedures to service your equipment.

We provide instructions for completing the form in the Declaration of Contamination of Vacuum equipment and Components – Procedure HS1.

Download the latest documents from [edwardsvacuum.com/HSForms/](http://edwardsvacuum.com/HSForms/), follow the procedure in HS1, fill in the electronic HS2 form, print it, sign it, and return the signed copy to us.

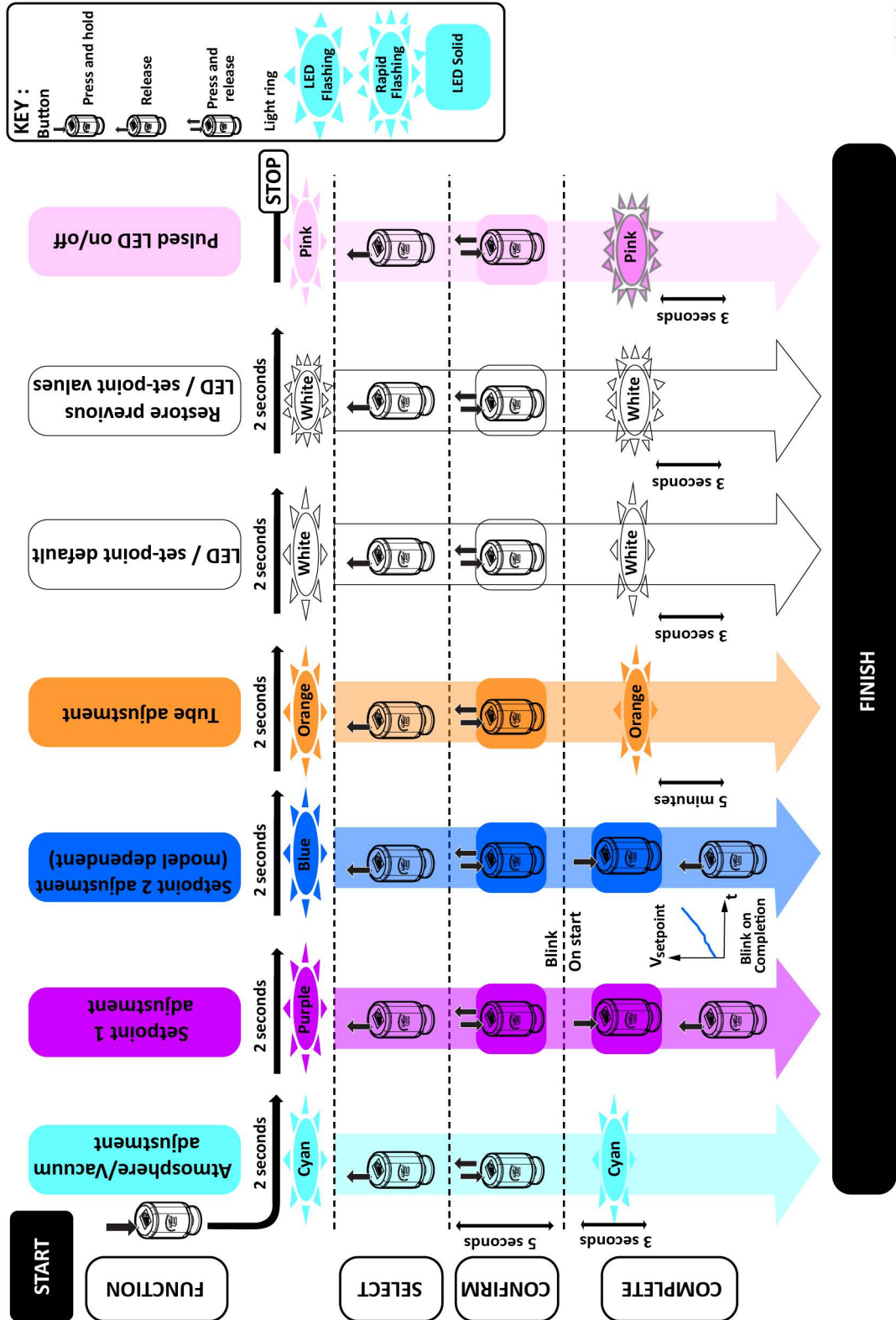


**NOTICE:**

**If we do not receive a completed HS2 form, your equipment cannot be serviced.**

# 12. Appendix - Multi-function button operation

Figure 22 Multi-function button operation



GE/3703/A

## EU Declaration of Conformity



This declaration of conformity is issued under the sole responsibility of the manufacturer:

**Edwards Ltd**

Innovation Drive  
Burgess Hill  
West Sussex  
RH15 9TW  
UK

**Documentation Officer**

Jana Sigmunda 300  
Lutín , 78349  
Czech Republic  
T: +42(0) 580 582 728  
[documentation@edwardsvacuum.com](mailto:documentation@edwardsvacuum.com)

APG200 Active Pirani Gauge  
nAPG200 Active Pirani Gauge

Is in conformity with the relevant Union harmonisation legislation:

- |            |   |
|------------|---|
| 2014/30/EU | Electromagnetic compatibility (EMC) directive<br>Class B Emissions, Industrial Immunity                         |
| 2011/65/EU | Restriction of certain hazardous substances (RoHS) directive<br>as amended by Delegated Directive (EU) 2015/863 |

Based on the requirements of relevant harmonised standards and technical documentation:

- |                   |   |
|-------------------|---|
| EN 61326-1:2013   | Electrical equipment for measurement, control and laboratory use. EMC requirements.<br>General requirements                                 |
| EN IEC 63000:2018 | Technical documentation for the assessment of electrical and electronic products with<br>respect to the restriction of hazardous substances |

This declaration, based on the requirements of the listed Directives and EN ISO/IEC 17050-1, covers all product serial numbers from this date on: *2022-06-21*

You must retain the signed legal declaration for future reference

This declaration becomes invalid if modifications are made to the product without prior agreement.



Nick Barratt - Engineering Manager, Eastbourne



Ed Neuss – General Manager, Eastbourne



## Declaration of Conformity

**Edwards Ltd**

Innovation Drive  
Burgess Hill  
West Sussex  
RH15 9TW  
UK

**Documentation Officer**

[documentation@edwardsvacuum.com](mailto:documentation@edwardsvacuum.com)

This declaration of conformity is issued under the sole responsibility of the manufacturer.

APG200 Active Pirani Gauge  
nAPG200 Active Pirani Gauge

The object of the declaration described above is in conformity with relevant statutory requirements:

Electromagnetic Compatibility Regulations 2016  
Class B Emissions, Industrial Immunity

Restriction of the Use of Certain Hazardous Substances in Electrical and Electronic Equipment Regulations 2012

Relevant designated standards or technical specifications are as follows:

EN 61326-1:2013	Electrical equipment for measurement, control and laboratory use. EMC requirements. General requirements
EN IEC 63000:2018	Technical documentation for the assessment of electrical and electronic products with respect to the restriction of hazardous substances

This declaration, based on the requirements of the listed Statutory Instruments and EN ISO/IEC 17050-1, covers all product serial numbers from this date on: 2022-06-21

You must retain the signed legal declaration for future reference

This declaration becomes invalid if modifications are made to the product without prior agreement.

**Signed for and on behalf of Edwards Ltd**



Nick Barratt - Engineering Manager, Eastbourne



Ed Neuss – General Manager, Eastbourne

## ADDITIONAL LEGISLATION AND COMPLIANCE INFORMATION

### RoHS (EU, UK): Material Exemption Information

This product is compliant with the following Exemptions

Annex III:

- 6(b) **Lead** as an alloying element in aluminium containing up to 0.4% by weight
- 6(c) Copper alloy containing up to 4% **lead** by weight
- 7(a) **Lead** in high melting temperature type solder (i.e. lead based alloys containing 85% by weight or more lead)
- 7(c) I Electrical and electronic components containing **lead** in a glass or ceramic other than dielectric ceramic in capacitors, e.g. piezoelectric devices, or in a glass or ceramic matrix compound

### REACH (EU, UK)

This product is a complex article which is not designed for intentional substance release. To the best of our knowledge the materials used comply with the requirements of REACH. The product manual provides information and instruction to ensure the safe storage, use, maintenance and disposal of the product including any substance based requirements.

### Article 33.1 Declaration (EU, UK)

This product contains Candidate List Substances of Very High Concern above 0.1%ww by article as clarified under the 2015 European Court of Justice ruling in case C-106/14.

- Lead (Pb)  
This substance is present in certain aluminium / brass / electrical or electronic components.

## Additional Applicable Requirements

The product is in scope for and complies with the requirements of the following:

2012/19/EU	Directive on waste electrical and electronic equipment (WEEE)
Product is certified to CSA-C22.2 No.61010-1-12	Safety requirements for electrical equipment for measurement, control and laboratory use – Part 1: General requirements TÜV Rheinland certificate no. CU72225965
Product is certified to UL61010-1 3 <sup>rd</sup> Edition	Safety requirements for electrical equipment for measurement, control and laboratory use – Part 1: General requirements TÜV Rheinland certificate no. CU72225965

## 材料成分声明

### China Material Content Declaration

部件名称 Part name	有害物质 Hazardous Substances					
	铅 Lead (Pb)	汞 Mercury (Hg)	镉 Cadmium (Cd)	六价铬 Hexavalent Chromium (Cr VI)	多溴联苯 Polybrominated biphenyls (PBB)	多溴二苯醚 Polybrominated diphenyl ethers (PBDE)
铸铝及铝合金制品 Aluminium alloys	X	O	O	O	O	O
印刷电路组件 (PCA) Printed Circuit Assembly (PCA)	X	O	O	O	O	O

O: 表示该有害物质在该部件的所有均质材料中的含量低于 GB/T 26572 标准规定的限量要求。

O: Indicates that the hazardous substance contained in all of the homogeneous materials for this part is below the limit requirement in GB/T 26572.

X: 表示该有害物质在该部件的至少一种均质材料中的含量超出 GB/T26572 标准规定的限量要求。

X: Indicates that the hazardous substance contained in at least one of the homogeneous materials used for this part is above the limit requirement of GB/T26572.



This page has been intentionally left blank.

This page has been intentionally left blank.

This page has been intentionally left blank.

