

Vacuum Solutions

Application Support

Service

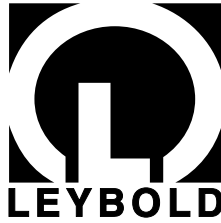

LEYBOLD VACUUM

GA 01.301/6.02

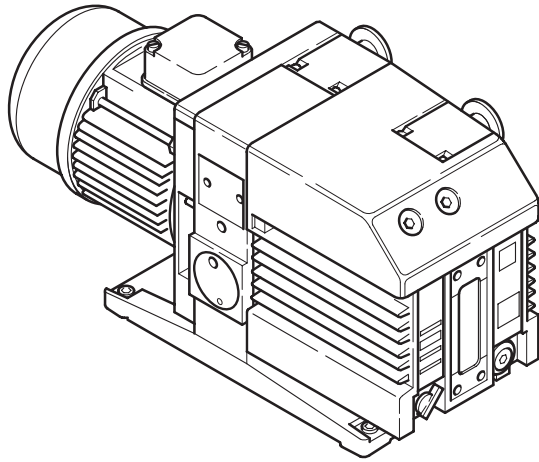

TRIVAC[®] BCS

Rotary Vane Vacuum Pump
D 40 BCS, D 65 BCS

- with mineral oil filling or
- with PFPE filling

Cat. No.
113 88/89/97/98/99
154 52/54

150
Years

Operating Instructions

Contents

	Page
IMPORTANT SAFETY CONSIDERATIONS . . .	4
1 Description	6
1.1 Function	7
1.2 Lubricants	9
1.3 Transportation	9
1.4 Supplied Equipment	9
1.5 Spare Parts	10
1.6 Accessories	10
1.6.1 Standard Accessories and Lubricants	10
1.6.2 TRIVAC System	11
1.7 Technical Data	12
1.7.1 Motor Dependent Data	13
2 Operation	14
2.1 Installation	14
2.2 Connection to the System	15
2.3 Electrical Connections	16
2.4 Start-up	17
2.4.1 Areas of Application	18
2.4.2 Notes for Pumps with EExe II T3 Motors	18
2.5 Operation	19
2.5.1 Pumping of Non-Condensable Gases	19
2.5.2 Pumping of Condensable Gases and Vapours	19
2.5.3 Operating Temperature	19
2.6 Switching Off/Shutdown	20
2.6.1 Shutdown through Monitoring Components	20
2.6.2 Failure of the Control System or the Mains Power	20
3 Maintenance	21
3.1 Checking the Oil Level	21
3.1.1 Checking the Condition of N 62 or HE 200 Oil	21
3.2 Oil Change	22
3.3 Cleaning the Dirt Trap	22
3.4 Removing and Fitting the Internal Demister	23
3.5 Disassembly and Reassembly of the Electric Motor	24
3.6 Replacing the Outer Shaft Seal	25
3.7 Removing and Remounting the Pump Module	26
3.7.1 Removing the Pump Module	26
3.7.2 Remounting the Pump Module	27
3.8 Leybold Service	28
3.8.1 Waste Disposal of Used Pump Materials	28
3.9 Storing the Pump	28
3.10 Maintenance Plan	29
4 Troubleshooting	30
EEC Declaration of Conformity	32

We reserve the right to modify the design and the specified data. The illustrations are not binding.



We strongly recommend that you read these Operating Instructions with care so as to ensure optimum operation of the pump right from the start.

Warning

Indicates procedures that must be strictly observed to prevent hazards to persons.



Caution

Indicates procedures that must strictly be observed to prevent damage to, or destruction of the pump.

Figures

The references to diagrams, e.g. (1/2) consist of the Fig. No. and the Item No. in that order.

Leybold-Service

If a pump is returned to LEYBOLD, indicate whether the pump is free of substances damaging to health or whether it is contaminated.

If it is contaminated also indicate the nature of the hazard. LEYBOLD must return any pumps without a „Declaration of Contamination“ to the sender’s address.

Disposal of Waste Oil

Owners of waste oil are entirely self-responsible for proper disposal of this waste.

Waste oil from vacuum pumps must not be mixed with other substances or materials.

Waste oil from vacuum pumps (Leybold oils which are based on mineral oils) which are subject to normal wear and which are contaminated due to the influence of oxygen in the air, high temperatures or mechanical wear must be disposed of through the locally available waste oil disposal system.

Waste oil from vacuum pumps which is contaminated with other substances must be marked and stored in such a way that the type of contamination is apparent. This waste must be disposed of as special waste.

European, national and regional regulations concerning waste disposal need to be observed. Waste must only be transported and disposed of by an approved waste disposal vendor.

IMPORTANT SAFETY CONSIDERATIONS

The Leybold TRIVAC BCS (PFPE) vacuum pump is designed for safe and efficient operation when used properly and in accordance with this manual. It is the responsibility of the user to carefully read and strictly observe all safety precautions described in this section and throughout the manual. This product must be operated and maintained by trained personnel only. Consult local, state, and national agencies regarding specific requirements and regulations. Address any further safety, operation and/or maintenance questions to your nearest Leybold Vacuum office.

Warning Failure to observe the following precautions could result in serious personal injury:



- Before beginning with any maintenance or service work on the TRIVAC BCS (PFPE), disconnect the pump from all power supplies.



- Do not operate the pump with any of the covers removed. Serious injury may result.
- If exhaust gases must be collected or contained, do not allow the exhaust line to become pressurised.
- Make sure that the gas flow from the exhaust port is not blocked or restricted in any way.



- The standard version of the TRIVAC BCS (PFPE) is not suited for operation in explosion hazard areas. Contact us before planning to use the pump under such circumstances.
- Before starting up for the first time, the motor circuit (3 phase) must be equipped with a suitable protective motor switch. Please take note of the information in these Operating Instructions or on the electric motor (wiring diagram).

- The TRIVAC BCS (PFPE) is not suited for pumping of:
 - combustible and explosive gases or vapours
 - radioactive and toxic substances
 - pyrophorous substances.

- Avoid exposing any part of the human body to the vacuum.
- Never operate the TRIVAC BCS (PFPE) without a connected intake line or blank flange.
- The location at which the TRIVAC BCS (PFPE) (including its accessories) is operated should be such that angles over 10° from the vertical are avoided.
- The location of the TRIVAC BCS (PFPE) should be such that all controls are easily accessible.



- Under certain ambient conditions the TRIVAC BCS (PFPE) may attain a temperature of over 80 °C (176 °F). There then exists the danger of receiving burns. Note the symbols on the pump pointing to the hazards, and in the case of a hot pump wear the required protective clothing.



- Before pumping oxygen (or other highly reactive gases) at concentrations exceeding the concentration in the atmosphere (> 21 % for oxygen) it will be necessary to use a special pump. Such a pump will have to be modified and de-greased, and an inert special lubricant (like PFPE) must be used.

Warning



- Before operating the TRIVAC BCS (PFPE) with atmospheric gas ballast (optional) check first compatibility with the pumped media so as to avoid hazardous conditions during operation right from the start.
- Before commissioning the TRIVAC BCS (PFPE), make sure that the media which are to be pumped are compatible with each other so as to avoid hazardous situations. All relevant safety standards and regulations must be observed.
- It is recommended to always operate the TRIVAC BCS (PFPE) with a suitable exhaust line which is properly connected. It must slope down and away from the pump.
- When moving the TRIVAC BCS (PFPE) always use the allowed means. A lifting eye is provided as standard on the pump.

Caution Failure to observe the following precautions could result in damage to the pump:

- Do **not** allow the ingestion of small objects (screws, nuts, washers, pieces of wire, etc.) through the inlet port. Always use the screen which is supplied with every pump.
- Do **not** use the pump for applications that produce abrasive or adhesive powders or condensable vapours that can leave adhesive or high viscosity deposits. Please contact Leybold Sales or Service to select a suitable separator. Also please contact Leybold Sales or Service when planning to pump vapours other than water vapour.
- This pump is suited for pumping water vapour within the specified water vapour tolerance limits.
- Avoid vapours that can condense into liquids upon compression inside the pump, if these substances exceed the vapour tolerance of the pump (> 25 mbar for water vapour).
- Before pumping vapours, the TRIVAC BCS (PFPE) should have attained its operating temperature, and the gas ballast should be set to position I (position 0 = closed, position I = max. water vapour tolerance, 25 mbar).
The pump will have attained its operating temperature about 30 minutes after starting the pump. During this time the pump should be separated from the process, by a valve in the intake line, for example.
- In the case of wet processes we recommend the installation of liquid separators upstream and downstream of the pump as well as the use of the gas ballast.
- The exhaust line should be laid so that it slopes down and away from the pump so as to prevent condensate from backstreaming into the pump. For this preferably use the flange on the side of the motor.
- The entry of particles and fluids must be avoided under all circumstances.
- Reactive or aggressive substances in the pump chamber may impair the operating oil or modify it. In addition, such substances may be incompatible with the materials of the pump (Viton, grey cast iron, aluminium, steel, resins, glass etc.).
- Corrosion, deposits and cracking of oil within the pump are not allowed.

Note This information will help the operator to obtain the best performance from the equipment:

- Normal amounts of humidity within the range of the pump's vapour tolerance will not significantly affect pump performance when the gas ballast is active. Preferably use the exhaust flange located on the side of the motor.

Caution:

In the case of custom pumps (with a Cat. No. deviating from the Cat No. stated in the EC Declaration of Conformity) please note the information provided on a separate sheet.

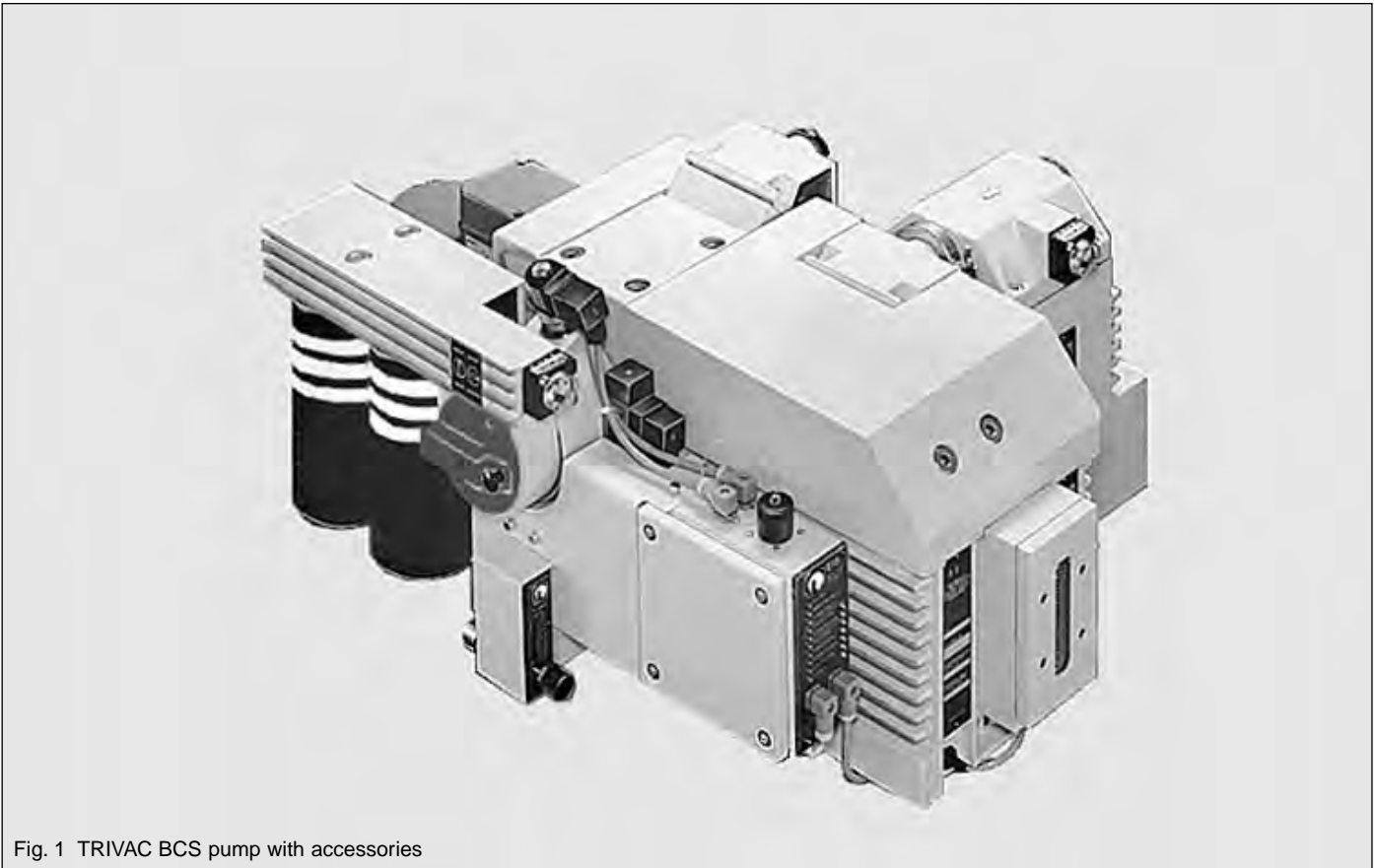

Fig. 1 TRIVAC BCS pump with accessories

1 Description

TRIVAC BCS pumps are oil-sealed rotary vane pumps. The TRIVAC D 40 BCS and D 65 BCS are dual-stage pumps. The number in the type designation (40 or 65) indicates the pumping speed in $\text{m}^3 \cdot \text{h}^{-1}$.

The TRIVAC BCS-PFPE have been prepared especially for operation with perfluoropolyther.

TRIVAC BCS pumps can pump gases and vapours, and evacuate vessels or vacuum systems in the fine vacuum range.

They have been designed particularly for use in connection with corrosive or aggressive media. Moreover, the pump has been prepared for the installation of an electric monitoring facility. Leybold have developed for the TRIVAC BCS a range of accessories which considerably extend the range of applications for this kind of pump. These accessories which in connection with the TRIVAC BCS vacuum pump make up the TRIVAC system, are described briefly in Chapter 1.6.

The drive motor of the TRIVAC BCS is directly flanged to the pump at the coupling housing. The pump and motor shafts are directly connected by a flexible coupling. The bearing points of the pump module are force lubricated sliding bearings. All controls as well as the oil-level glass and the nameplate are arranged on the front. All connections are to be found at the sides of the pump. The oil-level glass is provided with prisms for better observation of the oil level.

The pump module consists of assembly parts which are pin-fitted so as to allow easy disassembly and reassembly. The pump module can be easily removed without special tools.

Warning



Those of standard design are **not** suitable for pumping greater than atmospheric concentrations of oxygen.

Before pumping oxygen (or other highly reactive gases) at concentrations exceeding the concentration in the atmosphere (> 21 % for oxygen) it will be necessary to use a special pump. Such a pump will have to be modified and de-greased, and an inert special lubricant (like PFPE) must be used.

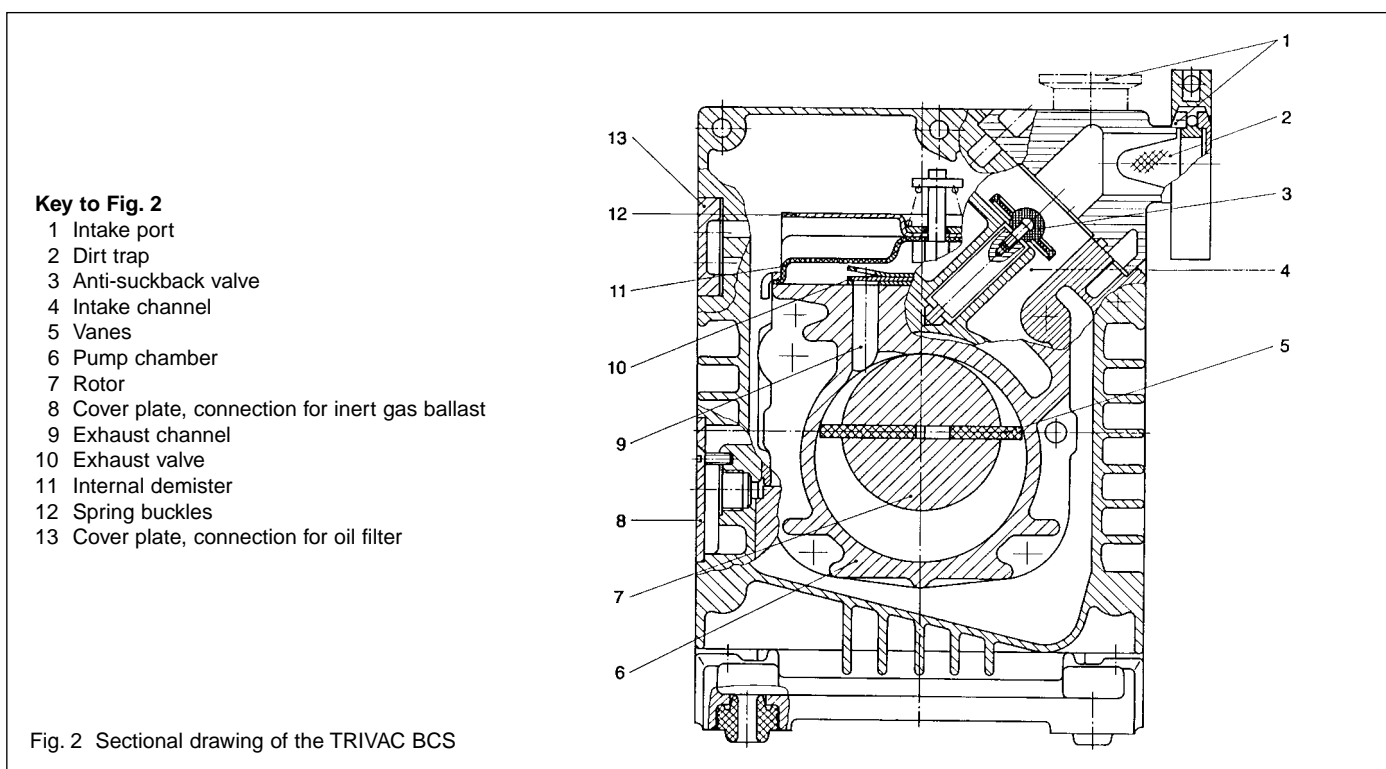

1.1 Function

The rotor (2/7), mounted eccentrically in the pump housing (2/6), has two radially sliding vanes (2/5) which divide the pump chamber into several compartments. The volume of each compartment changes periodically with the rotation of the rotor.

As a result, gas is sucked in at the intake port (2/1). The gas passes through the dirt trap sieve (2/2), flows past the open anti-suckback valve (2/3) and then enters the pump chamber. In the pump chamber, the gas is passed on and compressed, after the inlet aperture is closed by the vane.

The oil injected into the pump chamber is used for sealing and lubricating. The slap noise of the oil in the pump which usually occurs when attaining the ultimate pressure is prevented by admitting a very small amount of air into the pump chamber.

The compressed gas in the pump chamber is ejected through the exhaust valve (2/10). The oil entrained in the gas is coarsely trapped in the internal demister (2/11); there the oil is also freed of mechanical impurities. The TRIVAC BCS PFPE pumps do not have an internal demister. The gas leaves the TRIVAC BCS-PFPE through the exhaust port.

During compression, a controlled amount of air – the so-called gas ballast – can be allowed to enter the pump chamber by opening the gas ballast valve. The gas ballast stops condensation of vapours in the pump chamber up to the limit of the water vapour tolerance as specified in the technical data for the pump.

The gas ballast valve is opened (position I) and closed (position 0) by turning the gas ballast knob (7/5) on the front.

The gas ballast facility of the TRIVAC BCS pump has been prepared for connecting the inert gas system IGS, see Chapter 1.6.2.

To enable the TRIVAC BCS to be used at intake pressures as high as 1,000 mbar, a special lubricating system was developed featuring force-lubrication of the sliding bearings.

An oil pump (3/6) pumps the oil from the oil reservoir (3/5) into a pressure-lubrication system which supplies oil to all bearing points (3/2). From there the oil enters the pump chamber area (3/4) of the vacuum pump.

The oil pump is fitted in the front end plate on the coupling side of the pump module. The oil suction line is placed low, resulting in a large usable oil reservoir.

The oil is separated from the gas in the TRIVAC BCS in two steps as described above. First, small droplets are coalesced into large drops in the internal demister (2/11) fitted above the exhaust valve (2/10). Then, the large drops fall into the oil reservoir as the exhaust gas is diverted by the inner walls of the oil case. Thus a low loss of oil is obtained. This and the large usable oil reservoir ensure long intervals between oil changes even at high intake pressures.

Key to Fig. 3

- 1 Accessories
- 2 Bearings
- 3 Non-return valve
- 4 Pump chamber of the TRIVAC
- 5 Oil reservoir
- 6 Oil pump

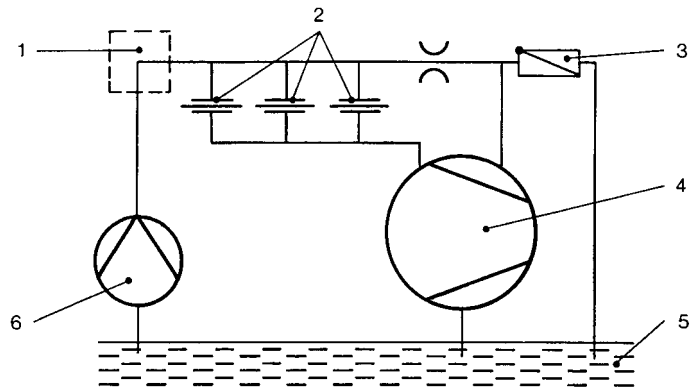
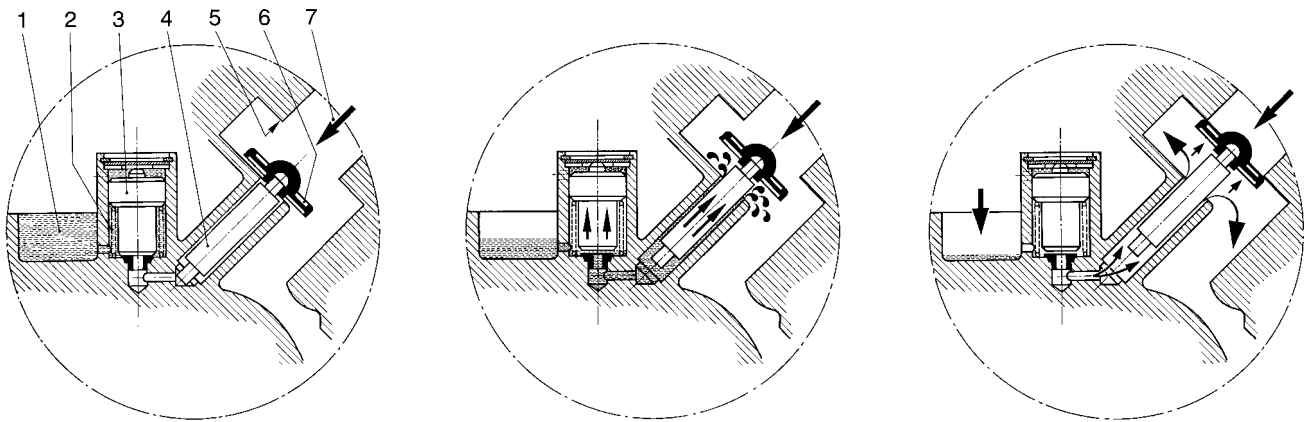

Fig. 3 Schematic of the lubricating system



Key to Fig. 4

- 1 Oil reservoir
- 2 Spring
- 3 Control piston
- 4 Anti-suckback piston
- 5 Valve seat
- 6 Valve disk
- 7 Gas inlet

Fig. 4 Hydropneumatic anti-suckback valve

The vacuum is maintained by the TRIVAC BCS through an integrated hydropneumatic anti-suckback valve (2/3) which is controlled via the oil pressure.

During operation of the TRIVAC BCS the control piston (4/3) remains sealed against a spring (4/2) by the oil pressure. The valve disc (4/6) of the anti-suckback valve is held at the lower position by its own weight (valve open). When the pump stops (because it has been switched off or because of a failure), the oil pressure drops and the spring (4/2) presses the control piston (4/3) up. Thus a connection is provided between the oil case or the oil reservoir (4/1) and the piston (4/4) of the anti-suckback valve.

Due to the pressure difference between the oil case and the intake port the oil presses the piston (4/4) up and the valve plate (4/6) against the valve seat (4/5). The quantity of oil in the oil reservoir (4/1) prevents the entry of air into the intake port (2/1) at the beginning of this process.

After the oil has flowed out from the reservoir and when the valve plate rests on the valve seat, air follows in, which vents the pump chamber and forces the valve disc (4/6) against its seat. This effectively prevents backstreaming of oil or oil vapours. The anti-suckback valve (2/3) operates independently of the operating mode of the pump, i.e. also with gas ballast.

All aluminium surfaces of the TRIVAC BCS are surface protected and thus particularly capable of resisting aggressive chemicals. A thermocouple has been incorporated in the pump which is used in connection with the optional electrical monitoring facility. The thermocouple may be accessed through the built-in connector (7/8).

Via a second oil fill opening, an exhaust line may be connected for venting the oil case when using the inert gas purging facility.

1.2 Lubricants

The standard TRIVAC BCS pumps are either ready for operation with mineral oil or with the special lubricant, perfluoropolyther (PFPE).

If mineral oil and PFPE come into contact they will emulsify. That's why the pumps must only be run with the type of lubricant specified for the pump. If you want to change the type of lubricant LEYBOLD should do the change.

In case of operation with mineral oil we recommend our vacuum pump oil N 62.

In case of operation with PFPE we recommend our vacuum pump oil NC 1/14.

When handling PFPE you should observe the following:

Warning During thermal decomposition at temperatures over 290 °C toxic and corrosive gases are released. When handling PFPE keep it way from open fires. Do not smoke in the work area.



Touch the inner sections of the pumps only while wearing clean gloves, and use clean tools;

Do the necessary work in clean and dry rooms;

After having removed the pump from its packaging, start it up as quickly as possible;

While working on the pump, do not eat, drink or smoke.

As cleaning agents solvents based on fluoroalkane compounds may be used.

When planning to use the pump with a different kind of lubricant contact us first.

The Operating Instructions GA 07.009 “PFPE for Vacuum Pumps“ will be enclosed with all TRIVAC BCS pumps. Observe the handling notes for PFPE collected in these Operating Instructions.

Given in Operating Instructions GA 07.009 are also the deviating specifications which apply to TRIVAC BCS pumps operated with PFPE.

Caution: In the case of custom pumps (with a Cat. No. deviating from the Cat No. stated in the EC Declaration of Conformity) please note the information provided on a separate sheet.

1.3 Transportation

- Warning**
- Pumps which are filled with operating agents must only be moved while standing upright. Otherwise oil may escape. Avoid any other orientations during transport.
 - Check the pump for the presence of any oil leaks, since there exists the danger that someone may slip on spilt oil.
 - When lifting the pump you must make use of the crane eyes provided on the pump for this purpose; also use the recommended type of lifting device.



1.4 Supplied Equipment

The equipment supplied with the TRIVAC BCS pump for operation with mineral oil includes:

Pump with motor, including initial filling of N 62 or HE-200 oil,

1 centering ring,

1 centering ring with dirt trap,

2 clamping rings DN 40 KF.

Plug without cable to protect the socket for the temperature switch.

For protection during shipment, the connection ports are each blanked off by rubber diaphragms and supporting rings.

Caution Upon delivery from Leybold Cologne the pumps will be filled with N62, in the case of pumps running on PFPE the lubricant NC 1/14 will be supplied in a separate container.

However, the pump will still contain residues of the NC 1/14 lubricant. In the D 40/65 BCS PFPE there will still be about 0.7 litres. The oil fill plugs have been screwed out and included separately.

The oil fill plugs have been removed and are supplied separately.

The pump is contained with some silica gel in an air-tight plastic bag.

Caution: In the case of custom pumps (with a Cat. No. deviating from the Cat No. stated in the EC Declaration of Conformity) please note the information provided on a separate sheet.

1.5 Spare Parts

Set of gaskets	197 42
Pump module, complete	
D 40 BCS	200 39 758
D 65 BCS	200 39 760
D 40 BCS-PFPE	200 39 154
D 65 BCS-PFPE	200 39 156
Module-gasket	239 73 039*)
Oil case gasket	200 09 148*)
Internal demister	390 26 014*)

*) included in gasket set

1.6 Accessories

1.6.1 Standard Accessories and Lubricants

	<i>Cat. No. / Ref. No.</i>
Separator AK 40-65, DN 40 KF	188 16
Exhaust filter AF 40-65, DN 40 KF	189 16
Drain tap for condensate trap, exhaust filter oil drain of the pump, vacuum-tight	190 90
oil-tight	190 90
Exhaust filter with lubricant return	
AR 40-65, DN 40 KF	189 22
Dust filter	186 15
Dust separator	186 16
Fine vacuum adsorption trap (with zeolite)	187 15
Adsorption trap (with aluminium oxide)	854 16
Oil filter OF 40-65	101 92
Chemical filter CF 40-65	101 97
Adaptor for RUVAC 151/251 Roots pumps	168 30
Adaptor for gas ballast port	
M 16 x 1.5 – DN 16 KF	168 40
M 16 x 1.5 – 3/8 inch NPT	99 175 011*)

Oil N 62	1 l	177 01
	5 l	177 02
	20 l	177 03

(Order through Leybold Cologne, Germany)

NC 1/14	1 l	177 38
HE 1600	10 lb	898 564
HE 200	1 qt	98 198 006
HE 200	12 qt case	98 198 049
HE 200	1 gal	98 198 007
HE 200	5 gal	98 198 008

(Order oil HE 200 through LHVP, Export, Pa, USA)

Oil grades N 62 and HE 200 are equivalent.

Special oils upon request.

Caution Use only the kind of oil specified by Leybold. Alternative types of oil upon request.

1.6.2 TRIVAC System

Leybold has developed the TRIVAC system especially for processes which depend on the reliability of the pump under difficult conditions (pumping of aggressive gases or vapours, for example).

Moreover, the pump status may be monitored continuously through visual and electric indicators.

The TRIVAC system consists of the TRIVAC BCS pump and the following accessories:

CFS 40-65 chemical filter w. safety separating valve Cat. No.:101 77

The CFS is a main flow lubricant filter incorporating a safety separating valve which may be exchanged while the pump continues to operate. The status of the interchangeable filters is indicated.

ARS 40-65 exhaust filter with lubricant return Cat. No.:189 57

The ARS filter collects the droplets of lubricant entrained in the exhaust gas and returns the collected lubricant back into the pump by means of a float controlled valve. This reduces the consumption of lubricant by the pump to an insignificant level so that a daily oil check will no longer be necessary. The status of the filter element may be checked at any time through the differential pressure indicator.

IGS 40-65 inert gas system Cat. No.:161 77

This accessory which may be controlled through a solenoid valve allows the definite injection of controlled quantities of gas into the TRIVAC BCS.

Thus it offers the possibility of effectively reducing contaminants in the lubricant of the system and the materials of the system itself.

LSS 40-65 limit switch system Cat. No.:161 07

This accessory consists of a package of limit switches and serves the purpose of monitoring the operation of the system.

Included with the limit switch system are one each:

- oil pressure switch (operating pressure)
- float switch (oil level monitoring)
- flow switch (inert gas)
- differential pressure switch (chemical filter)
- pressure switch (exhaust filter)
- connection cable for the built-in temperature switch

EIS 40-65 electrical indicator system Cat. No.:160 97

This accessory combines all switch status signals and indicates the status of these switches through LEDs: "GREEN" for normal operation, "RED" for fault. Through a multi-way connector all signals may be accessed for transmission to a remote processing unit.

1.7 Technical Data

TRIVAC BCS		D 40 BCS two-stage	D 65 BCS two-stage
Nominal pumping speed ¹⁾	m ³ · h ⁻¹ (cfm)	46 (27.1)	75 (44.2)
Pumping speed ¹⁾	m ³ · h ⁻¹ (cfm)	40 (23.6)	65 (38.3)
Ult. partial pr. without gas ballast ¹⁾	mbar	10 ⁻⁴	10 ⁻⁴
	Torr	0.75 · 10 ⁻⁴	0.75 · 10 ⁻⁴
Ultimate total pr. without gas ballast ¹⁾	mbar	< 2 · 10 ⁻³	< 2 · 10 ⁻³
	Torr	< 1.5 · 10 ⁻³	< 1.5 · 10 ⁻³
Ultimate total pr. with gas ballast ¹⁾	mbar	< 5 · 10 ⁻³	< 5 · 10 ⁻³
	Torr	< 3.8 · 10 ⁻³	< 3.8 · 10 ⁻³
Water vapour tolerance ¹⁾	mbar (Torr)	40 (30)	40 (30)
Oil filling, min./max.	l	1.7/2.6	2.0/3.3
Connections	DN	40 KF	40 KF
Motor protection	IP	54	54
Weight *	kg (lbs)	68 (149.9)	80 (176.4)
Motor power *	W	1500	2200
Noise level * to DIN 45 635 without/with gas ballast	dB (A)	57/59	57/59

TRIVAC BCS with three-phase motor

230/400 V, 50 Hz / 250/440 V, 60 Hz

Cat. No. 113 88

Cat. No. 113 98

TRIVAC BCS-PFPE		D 40 BCS-PFPE two-stage	D 65 BCS-PFPE two-stage
Nominal pumping speed ¹⁾	m ³ · h ⁻¹ (cfm)	46 (27.1)	75 (44.2)
Pumping speed ¹⁾	m ³ · h ⁻¹ (cfm)	40 (23.6)	65 (38.3)
Ultimate partial pr. without gas ballast ¹⁾	mbar	< 8 · 10 ⁻⁴	< 8 · 10 ⁻⁴
	Torr	< 6 · 10 ⁻⁴	< 6 · 10 ⁻⁴
Ultimate total pressure w. gas ballast ¹⁾	mbar	< 5 · 10 ⁻³	< 5 · 10 ⁻³
	Torr	< 3.8 · 10 ⁻³	< 3.8 · 10 ⁻³
Lubricant filling min./max. upon delivery	l	1.5/2.5	2.0/3.5
	l	0.6	0.75
Connections	DN	40 KF	40 KF
Motor protection	IP	54	54
Weight *	kg (lbs)	71 (156.6)	83 (183)
Motor power *	W	2200	2200
Noise level * to DIN 45 635, without/with gas ballast	dB (A)	57/59	57/59

TRIVAC BCS-PFPE with three-phase motor

230/400 V, 50 Hz / 250/440 V, 60 Hz

Cat. No. 113 89

Cat. No. 113 99

200/400 V, 50 Hz / 200/400 V, 60 Hz

Cat. No. 154 52

Cat. No. 154 54

¹⁾ To DIN 28 400 and subsequent numbers

* Length, weight, motor power and noise level for the models with three-phase motor.

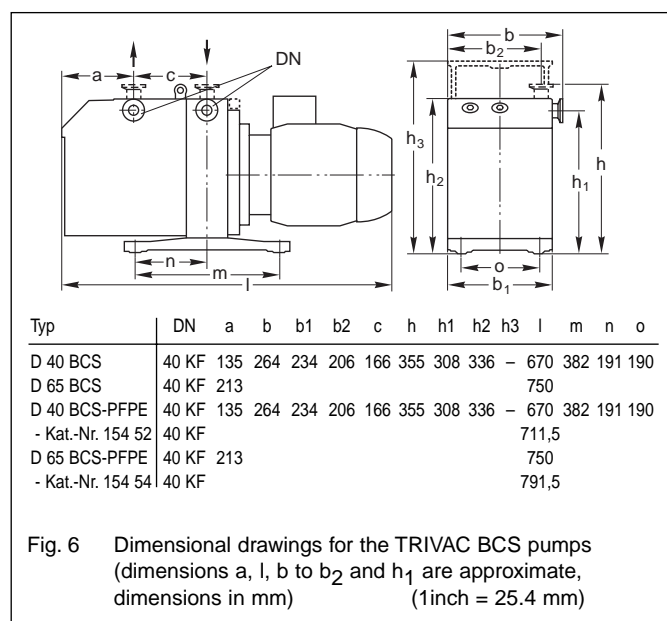
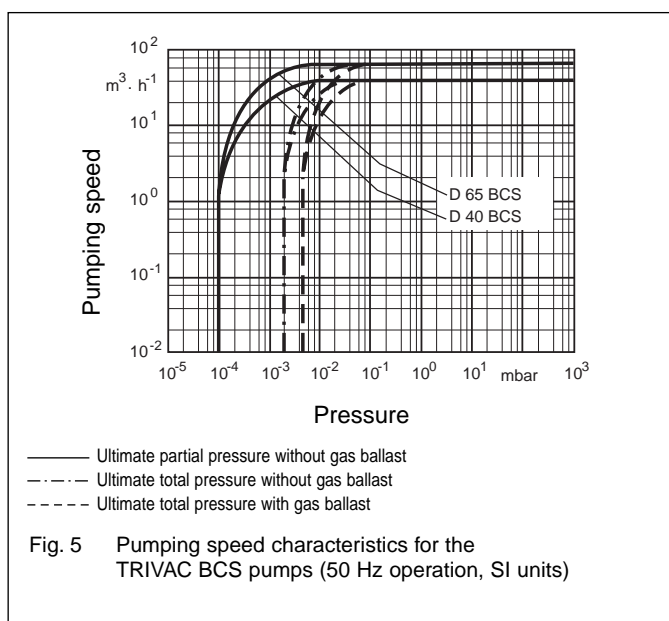

1.7.1 Motor Dependent Data

D 40 BCS	Ref. No.	Nom. voltage (V)	Frequ. (Hz)	Voltage range (V)	Power (kW)	Nom. current (A)	Size	Region
Cat. No. 113 88	380 66 011 3~	230/400 250/440	50 60	218-242/380-420 240-277/414-480	1.5	6.15/3.55 5.45/3.15	90	Euro (USA)

D 65 BCS	Ref. No.	Nom. voltage (V)	Frequ. (Hz)	Voltage range (V)	Power (kW)	Nom. current (A)	Size	Region
Cat. No. 113 98	380 66 012 3~	230/400 250/440	50 60	218-242/380-420 240-277/414-480	2.2	8.65/5.0 7.8/4.5	90	Euro (USA)

D 40 BCS-PFPE	Ref. No.	Nom. voltage (V)	Frequ. (Hz)	Voltage range (V)	Power (kW)	Nom. current (A)	Size	Region
Cat. No. 113 89	380 66 012 3~	230/400 250/440	50 60	218-242/380-420 240-277/414-480	2.2	8.65/5.0 7.8/4.5	90	Euro (USA)
Cat. No. 154 52	200 15 402 3~	200/400 200/400	50 60	190-220/380-440 190-240/380-480	2.2	11,8/5,9 10/5	100	Wide voltage

D 65 BCS-PFPE	Ref. No.	Nom. voltage (V)	Frequ. (Hz)	Voltage range (V)	Power (kW)	Nom. current (A)	Size	Region
Cat. No. 113 99	380 66 012 3~	230/400 250/440	50 60	218-242/380-420 240-277/414-480	2.2	8.65/5.0 7.8/4.5	90	Euro (USA)
Cat. No. 113 97	200 10 412 3~	200/346 208/360	50 60	190-210/330-365 190-230/330-400	2.2	10,1/5,85 10,1/5,85	90	Japan, South and Central America (USA)
Cat. No. 154 54	200 15 402 3~	200/400 200/400	50 60	190-220/380-440 190-240/380-480	2,2	11,8/5,9 10/5	100	Wide voltage

Caution: In the case of custom pumps (with a Cat. No. deviating from the Cat No. stated in the EC Declaration of Conformity) please note the information provided on a separate sheet.

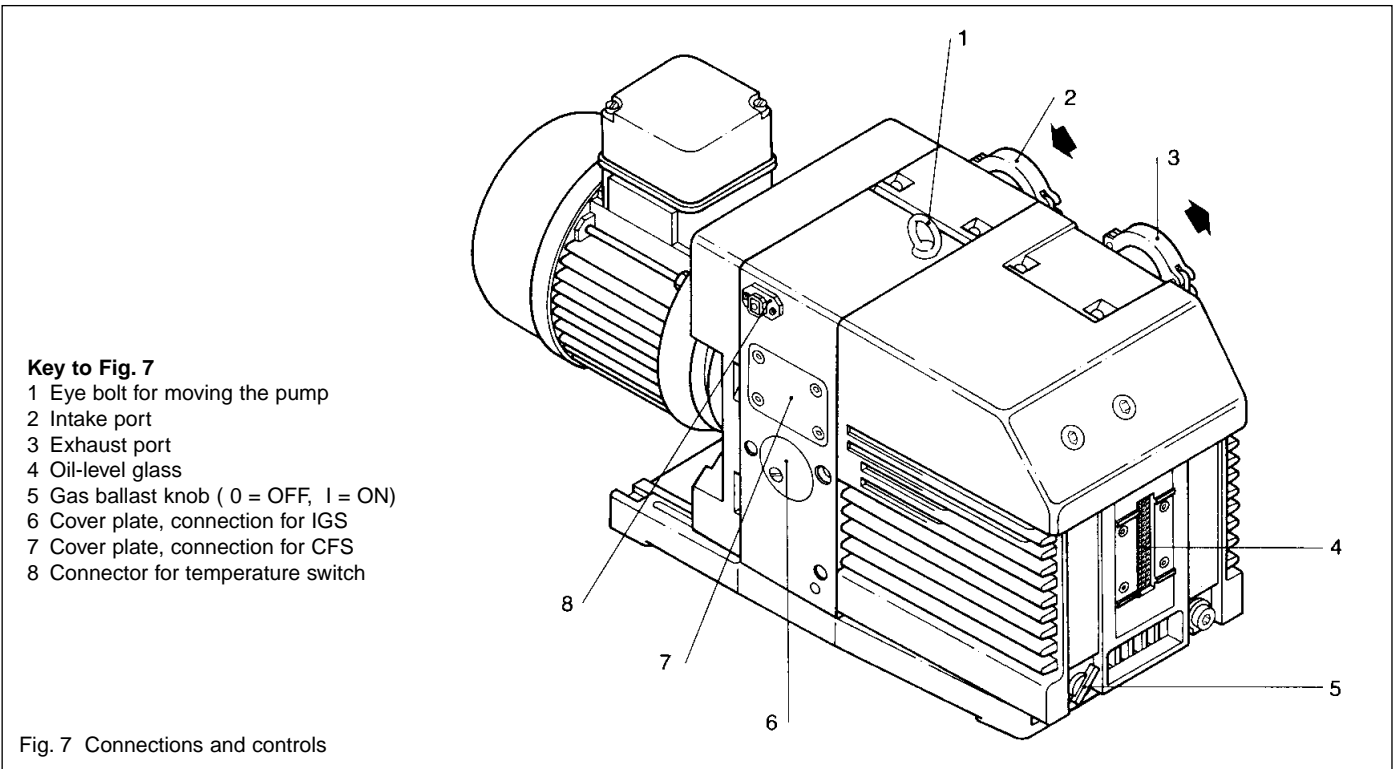

2 Operation

2.1 Installation

Warning The standard pump is not suited for installation in explosion hazard areas. When planning such an application please contact us first.



The TRIVAC BCS pump can be set freely up on a flat, horizontal surface. Rubber feet under the coupling housing ensure that the pump can not slip.

Caution A fully assembled TRIVAC system D 65 must not be lifted at the eye bolt (7/1). First unscrew the eye bolt and fit an adaptor with a stronger eye bolt (Ref. No. 200 09 675).

If you wish firmly install the pump in place, insert bolts or similar through the bore holes in the rubber feet.

The rubber feet act as vibration absorbers. They must therefore not be compressed by bolts.

Caution When installing the TRIVAC BCS pump, make sure that the connections and controls are readily accessible.

Max. tilt for the pump (without further attachment) with possibly fitted standard accessories is 10° from the vertical.

The site chosen should allow adequate air circulation to cool the TRIVAC BCS (keep front and rear unobstructed). The ambient temperature should not exceed +40 °C (104 °F) and not drop below +12 °C (55 °F) (see Chapter 2.5.3).

The max. amount of heat given off approximately corresponds to the rated motor power.

2.2 Connection to the System

Warning When operating the pump with PFPE observe the additional information provided in Chapter 1.2 and Operating Instructions GA 07.009.



Before connecting the TRIVAC BCS, remove the shipping seals from the connection flanges (7/2) and (7/3).

Note Retain the shipping seals in case you need to store the pump in the future.

The pump is shipped with intake and exhaust flanges mounted for horizontal connection of the connecting lines. You can easily convert the ports for vertical connection by removing the four capscrews, rotating the flanges as required, and reinstalling the capscrews. Connect the intake and exhaust lines with a centering ring and a clamping ring each. Use the centering ring with dirt trap for the intake port.

Connect the intake and exhaust line using anti-vibration bellows, without placing any strain on the pump.

Caution The intake line must be clean. Deposits in the intake line may outgas and adversely affect the vacuum. The connecting flanges must be clean and undamaged. The maximum throughput of the pump is equivalent to the pumping speed of the pump (see Chapter 1.6). The cross-section of the intake and exhaust lines should be at least the same size as the connection ports of the pump. If the intake line is too narrow, it reduces the pumping speed. If the exhaust line is too narrow, overpressures may occur in the pump; this might damage the shaft seals and cause oil leaks. The maximum pressure in the oil case must not exceed 1.5 bar (absolute).

When pumping vapours, it is advisable to install condensate traps on the intake and exhaust sides.

Install the exhaust line with a **downward slope** (lower than the pump) so as to prevent condensate from flowing back into the pump. If this is not possible, insert a condensate trap.

Caution When oil mist is to be removed from the exhaust flow we recommend the use of the exhaust filter with lubricant return (ARS) which is part of the TRIVAC system.

When pumping aggressive media in particular in connection with PFPE as the lubricant, we recommend the use of the chemical filter with safety separating valve (CFS) which is part of the TRIVAC system. This will considerably extend the service life of the lubricant.

The inlet pressure for the gas ballast should be about 1000 mbar (absolute) and sufficient quantities of gas must be available (about $\frac{1}{10}$ of the pumping speed).

Warning Never operate the pump with a sealed exhaust line. There is the danger of injury.



Before starting any work on the pump, the personnel must be informed about possible dangers first. All safety regulations must be observed.

Depending on the type of application or the kind of pumped media, the corresponding regulations and information sheets must be observed.

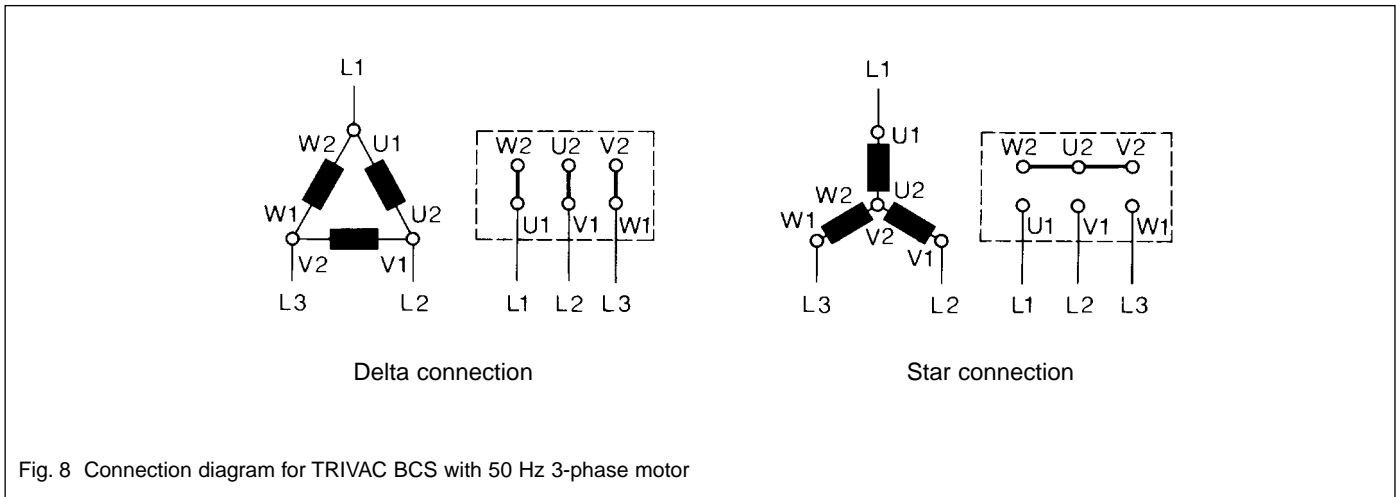

Fig. 8 Connection diagram for TRIVAC BCS with 50 Hz 3-phase motor

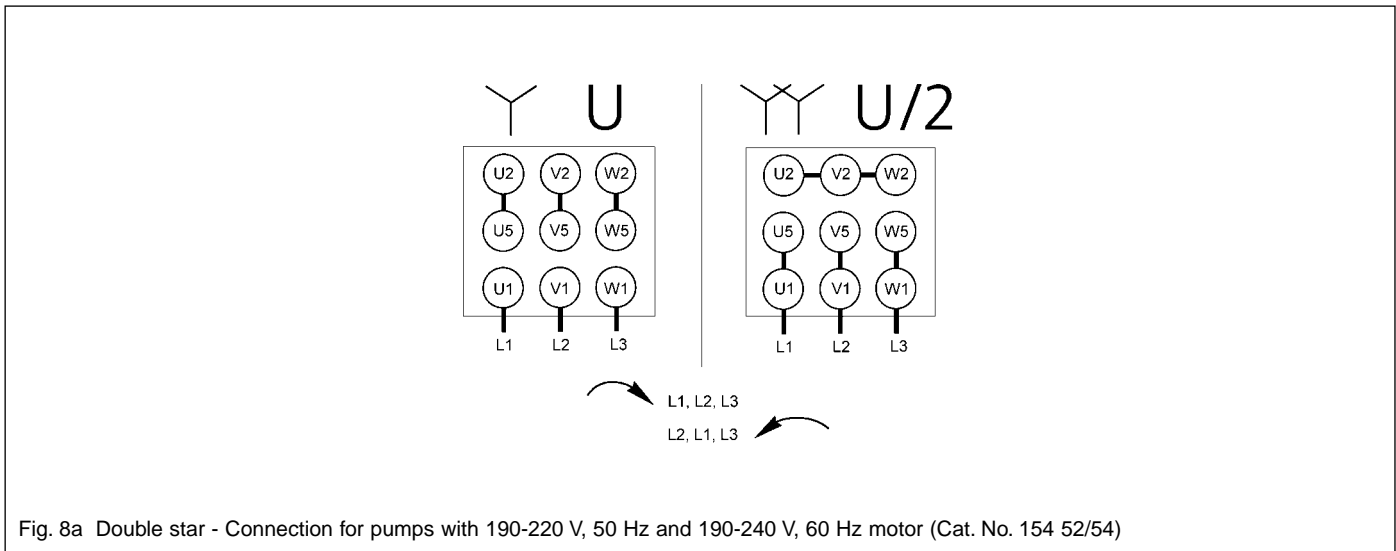

Fig. 8a Double star - Connection for pumps with 190-220 V, 50 Hz and 190-240 V, 60 Hz motor (Cat. No. 154 52/54)

2.3 Electrical Connections

Warning Before beginning with any work on the wiring, ensure that mains supply for the pump is off. Electrical connections must be done by a qualified electrician as defined by VDE 0105 in accordance with the VDE 0100 guidelines.



TRIVAC BCS pumps are supplied with three-phase motor but without accessories for electrical connection. They must be connected via the appropriate cable, and a suitable motor protection switch.

Set the switch in accordance with the rating on the motor nameplate.

Fig. 8 shows the connection for pumps with 230/380 V, 50 Hz motors. In the case of pumps equipped as standard with a 60 Hz motor, please observe the diagram on or at the motor.

Caution After connecting the motor and after every time you alter the wiring, check the direction of rotation. To do so, briefly switch on the motor and check whether a suitable cover (e. g. a blank flange) is sucked on at the intake port. If not, interchange two phases of the connection.
Observe the direction arrow on the coupling housing.

If the connector for the temperature switch is not used, the plug may remain connected at this socket to protect it. However, there is the danger that the protruding plug may be damaged.

The built-in temperature switch provides a signal when the pump gets too hot. We recommend that you access the signal available at this connector through the LSS and the EIS (see Chapter 1.6.2). Otherwise you may access the signal at pins 1 and 2 (voltage 24 V DC max., power consumption 10 W).

Caution: In the case of custom pumps (with a Cat. No. deviating from the Cat No. stated in the EC Declaration of Conformity) please note the information provided on a separate sheet.

2.4 Start-up

Warning Each time before starting up check the oil level.



Open all valves blocking the exhaust lines. The pump must never be operated with a blocked or constricted exhaust line.

For pumps with 3-phase motors, check the direction of rotation before starting the pump for the first time and after each change in the electrical connection (see Chapter 2.3).

On initial start-up, after prolonged idle periods or after an oil change, the specified ultimate pressure cannot be attained until the oil is degassed.

This can be done by running the pump for approx. 30 min. with the intake line closed and the gas ballast valve (7/5) open.

If the chemical filter (CFS) has been installed on the pump (see Chapter 1.6.2) the separating valve may be set to the position marked "Wechsel" during the first part of the run-up phase. When doing so, the relatively cold and thick lubricant will not have to be pumped through the interchangeable filter, thus removing some load from the pump's motor. Thereafter, the separating valve is set to the position "Betrieb".

Warning Before starting the pump ensure that the pump and the fitted accessories meet the requirements of your application and that safe operation can be guaranteed.



Avoid exposure of any part of the body to the vacuum. There is the danger of injury. Never operate the pump with an open intake port. Vacuum connections as well as oil-fill and oil-drain openings must never be opened during operation.

The safety regulations which apply to the application in each case must be observed. This applies to installation, operation and during maintenance (service) as well as waste disposal and transportation.

The standard pump is not suited for pumping of hazardous gases or vapours.

Our technical sales department is available for further advice in these matters.

2.4.1 Areas of Application



Warning Before pumping oxygen (or other highly reactive gases) at concentrations exceeding the concentration in the atmosphere (> 21 % for oxygen) it will be necessary to use a special pump. Such a pump will have to be modified and de-greased, and an inert special lubricant (like PFPE) must be used.

The pump is not suitable for pumping of:

- ignitable and explosive gases or vapours
- oxidants
- pyrophorous gases.

Caution The pumps are not suitable for pumping of liquids or very dusty media. Suitable protective devices must be installed.

Our technical sales department is available for further advice in these matters.

2.4.2 Notes for Pumps with EExe II T3 Motors

There are no reservations as to operation of the vacuum pump in explosion hazard areas of outer ZONE 1 for substances of temperature classes T1 to T3 and explosion group IIA and IIB when observing the conditions given in the following:



Warning

- The electric motor of the vacuum pump must be connected through a suitable motor protection switch to the mains supply. If the vacuum pump is supplied ready for connection, the motor protection switch needs to be installed by the customer on the vacuum pump and within a pressure-tight encapsulation.

- The electric motor must be installed in accordance with the accepted rules which apply to electrical systems in explosion hazard areas. If required, detailed information on this is available from the manufacturer.

- In case of a failure relating to the vacuum, the vacuum pump must be switched off automatically by interrupting the power supply.



- Due to the measures introduced, the vacuum pump is **not** suited for pumping explosive atmospheres (inner explosion protection). If planning such an application please consult us first.

2.5 Operation

TRIVAC BCS pumps can pump condensable gases and vapours, provided that the gas ballast valve (7/5) is open and the pump has attained its operating temperature.

In connection with the inert gas system (IGS) which is part of the TRIVAC System, TRIVAC BCS pumps may be operated with an inert gas ballast.

Since the IGS is intended for a reduced gas ballast for purging the pump, the water vapour tolerance of the pump is reduced depending on the settings to values in the 1 mbar range.

The inert gas supply needs to be opened before allowing the process gas to enter into the pump.

2.5.1 Pumping of Non-Condensable Gases

If the process contains mainly permanent gases, the TRIVAC BCS may be operated without gas ballast (position 0), provided that the saturation vapour pressure at operating temperature is not exceeded during compression.

If the composition of the gases to be pumped is not known and if condensation in the pump cannot be ruled out, run the pump with the gas ballast valve open in accordance with Chapter 2.5.2.

2.5.2 Pumping of Condensable Gases and Vapours

With the gas ballast valve open (position I) and at operating temperature, TRIVAC BCS pumps can pump pure water vapour up to the water vapour tolerance specified by the technical data. If the vapour pressure increases above the permissible level, the water vapour will condense in the oil of the pump.

When pumping vapours ensure that the gas ballast valve is open and that the pump has warmed up for approximately 30 minutes with the intake line closed.

Caution Vapour phases may only be pumped up to the permissible limit after the pump has attained its operating temperature.

During pumping, vapours may dissolve in the oil. This changes the oil's properties and thus there is a risk of corrosion in the pump. Therefore, don't switch off the pump immediately after completion of the process. Instead, allow the TRIVAC BCS to continue operating with the gas ballast valve open and the intake line closed until the oil is free of condensed vapours.

We strongly recommend operating the pump in this mode for about 30 minutes after completion of the process.

In cyclic operation, the TRIVAC BCS should not be switched off during the intervals between the individual working phases (power consumption is minimal when the pump is operating at ultimate pressure), but should continue to run with gas ballast valve open and intake port closed (if possible via a valve).

Once all vapours have been pumped off from a process (e.g. during drying), the gas ballast valve can be closed to improve the attainable ultimate pressure.

2.5.3 Operating Temperature

Proper operation of the TRIVAC BCS is ensured in the ambient temperature range between 12 °C (55 °F) to 40 °C (104 °F).

Warning At operating temperature, the surface temperature of the oil case may lie between 40 °C (104 °F) and over 100 °C (212 °F), depending on the load. There is the danger of receiving burns.



If – due to the ambient conditions – this temperature range is exceeded at either end of the range, then the operating range of the TRIVAC BCS can be adapted.

The Leybold sales department will be pleased to answer any questions in this matter.

2.6 Switching Off/ Shutdown

Since the TRIVAC BCS pump will commonly be exposed to aggressive and corrosive media, we recommend that you let the pump continue to operate even during long non-working intervals (e.g. overnight) with the intake line closed and the gas ballast valve open. This avoids corrosion during idle periods and difficulties when re-starting the pump under conditions where the lubricant has been chemically modified.

Caution When pumping condensable media let the pump continue to operate with the gas ballast valve open and the intake line closed before switching off (see Chapter 2.5.2). When using PFPE as the lubricant you must note the information given in Operating Instructions GA 07.009 when switching the pump off or shutting it down for a longer period of time.

If the TRIVAC BCS running with mineral oil is to be shut-down for an extended period after pumping aggressive or corrosive media or if the pump has to be stored, proceed as follows:

Warning When pumping harmful substances, take adequate safety precautions.



Our technical sales department is available for further advice in these matters.

Drain the oil (see Chapter 3.2).

Add clean oil until the oil-level is at the "min" mark (see Chapter 3.2) and let the pump operate for some time.

Then drain the oil and add clean oil until the oil level is at the "max." mark (see Chapter 3.2).

Seal the connection ports. Special conservation or anti-corrosion oils aren't necessary.

Caution Please also take note of the information given in Chapter 3.9 (Storing the Pump).

2.6.1 Shutdown through Monitoring Components

Warning When the pump has been switched off due to overheating sensed by the motor coil protector, the pump must only be started manually after the pump has cooled down to the ambient temperature and after having removed the cause first.



2.6.2 Failure of the Control System or the Mains Power

Warning In order to prevent the pump from running up unexpectedly after a mains power failure, the pump must be integrated in the control system in such a way that the pump can only be switched on again manually. This applies equally to emergency cut-out arrangements.



3 Maintenance

Warning Disconnect the electrical connections before disassembling the pump. Make absolutely sure that the pump cannot be accidentally started.



If the pump has pumped harmful substances, ascertain the nature of hazard and take adequate safety measures.



Observe all safety regulations.

If you send a pump to LEYBOLD for repair please observe the information provided in Chapter 3.8.

Caution When using PFPE as the lubricant please observe all instructions given in Chapter 1.2 and in Operating Instructions GA 07.009. When disposing of used oil, you must observe the applicable environmental regulations!

Due to the design concept, TRIVAC BCS pumps require very little maintenance when operated under normal conditions. The work required is described in the sections below.

Caution All work must be carried out by suitably trained personnel. Maintenance or repairs carried out incorrectly will affect the life and performance of the pump and may cause problems when filing warranty claims.

LEYBOLD offers practical courses on the maintenance, repair, and testing of TRIVAC BCS pumps. Further details are available from LEYBOLD on request.

Caution If the TRIVAC BCS is used in ambient air which is much contaminated, make sure that the air circulation and the gas ballast valve are not adversely affected.

When the TRIVAC BCS has been pumping corrosive media we recommend that possibly planned maintenance work be carried out immediately in order to prevent corrosion of the pump while it is at standstill.

For spare parts numbers please refer to the enclosed Spare Parts List. In the case of custom models and special versions, please always state the number of the custom model or version together with its serial number.

3.1 Checking the Oil Level

During operation of the TRIVAC BCS the oil level must always remain between marks (9/2) and (9/3) at the oil-level glass. The amount of oil must be checked and topped up as required.

Caution Fill in oil only after the pump has been switched off.

When operating the TRIVAC BCS in connection with the exhaust filter with lubricant return (ARS 40-65) the checking intervals are extended (see Chapter 1.6.2).

When using the oil float switch (LSS) remote monitoring of the lubricant is possible (see Chapter 1.6.2).

When properly used, PFPE is not subject to any wear. Thus it will not be required to exchange the PFPE lubricant. Possible contamination is filtered out by the chemical filter (CFS). The lubricant becomes turbid when contaminated. You must exchange the filter in such a case.

3.1.1 Checking the Condition of N 62 or HE 200 Oil

The ageing process for the standard operating fluid N 62 resp. HE 200 (see Chapter 1.2.1) will depend very much on the area of application for the pump.

a) Visual check

Normally the oil is clear and transparent. If the oil darkens, it should be changed.

b) Chemical check

The neutralisation number of N 62 oil is determined according to DIN 51558. If it exceeds 2, the oil should be changed.

c) Viscosity check

If the viscosity of N 62 at 25 °C exceeds a level of 240 mPas (20% higher than the viscosity of fresh oil) an oil change is recommended.

If gases or liquids dissolved in the oil result in a deterioration of the ultimate pressure, the oil can be degassed by allowing the pump to run for approx. 30 min. with the intake port closed and the gas ballast valve open.

When wanting to check the oil, switch off the pump first and drain out from the warm pump the required amount of oil through the oil drain (9/4) into a beaker or similar.

Note Please note the safety information given in Chapter 3.2.

3.2 Oil Change

(not required for PFPE)

Warning

Before pumping oxygen (or other highly reactive gases) at concentrations exceeding the concentration in the atmosphere (> 21 % for oxygen) it will be necessary to use a special pump. Such a pump will have to be modified and de-greased, and an inert special lubricant (like PFPE) must be used.



Hazardous substances may escape from the pump and the oil. Take adequate safety precautions. For example wear gloves, face protection or breathing protection.



Observe all safety regulations.

For proper operation of the pump, it is essential that the pump has an adequate supply of the correct and clean oil at all times.

The oil must be changed when it looks dirty or if it appears chemically or mechanically worn out (see Chapter 3.1.1).

The oil should be changed after the first 100 operating hours and then at least every 2,000 to 3,000 operating hours or after one year. At high intake pressures and intake temperatures and/or when pumping contaminated gases, the oil will have to be changed more frequently.

Further oil changes should be made before and after long-term storage of the pump.

If the oil becomes contaminated too quickly, install a dust filter and/or oil filter (see Chapter 1.6).

Contact us for more information in this matter.

Required tool:

Allen key size 8.

Caution

Only change the oil after the pump has been switched off and while the pump is still warm.

Warning

If there is the danger that the operating agent may present a hazard in any way due to decomposition of the oil, or because of the media which have been pumped, you must determine the kind of hazard and ensure that all necessary safety precautions are taken.

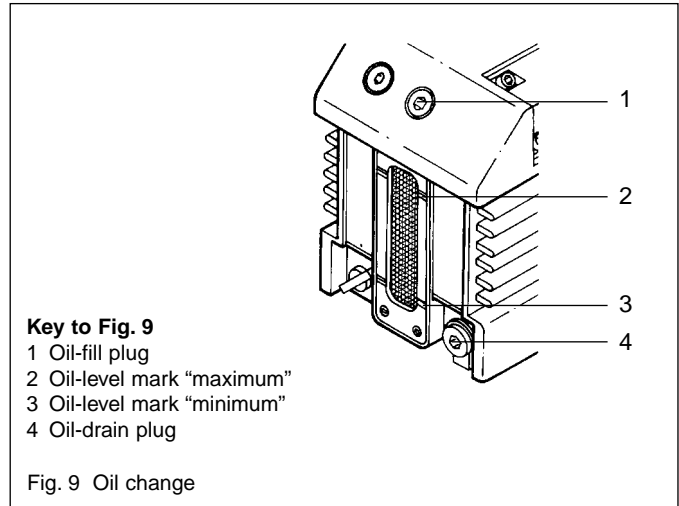

Remove the oil-drain plug (9/4) and let the used oil drain into a suitable container. When the flow of oil slows down, screw the oil-drain plug back in, briefly switch on the pump (max. 10 s) and then switch it off again. Remove the oil-drain plug once more and drain out the remaining oil.

Screw the oil-drain plug back in (check the gasket and reinstall a new one if necessary).

Remove the oil-fill plug (9/1) and fill in fresh oil.

Screw the oil-fill plug (9/1) back in.

When an exhaust filter with lubricant return has been installed on the pump (see Chapter 1.6.2) please also exchange the oil there.

Caution

We can only guarantee that the pump operates as specified by the technical data if the lubricants recommended by us are used.

3.3 Cleaning the Dirt Trap

A wire-mesh sieve is located in the intake port of the pump to act as a dirt trap for foreign objects. It should be kept clean to avoid a reduction of the pumping speed.

For this purpose, remove the dirt trap (2/2) from the intake port and rinse it in a suitable vessel with solvent. Then thoroughly dry it with compressed air.

If the dirt trap is defective, replace it with a new one.

Caution

The cleaning intervals depend on the application. If the pump is exposed to large amounts of abrasive materials, a dust filter should be fitted into the intake line.

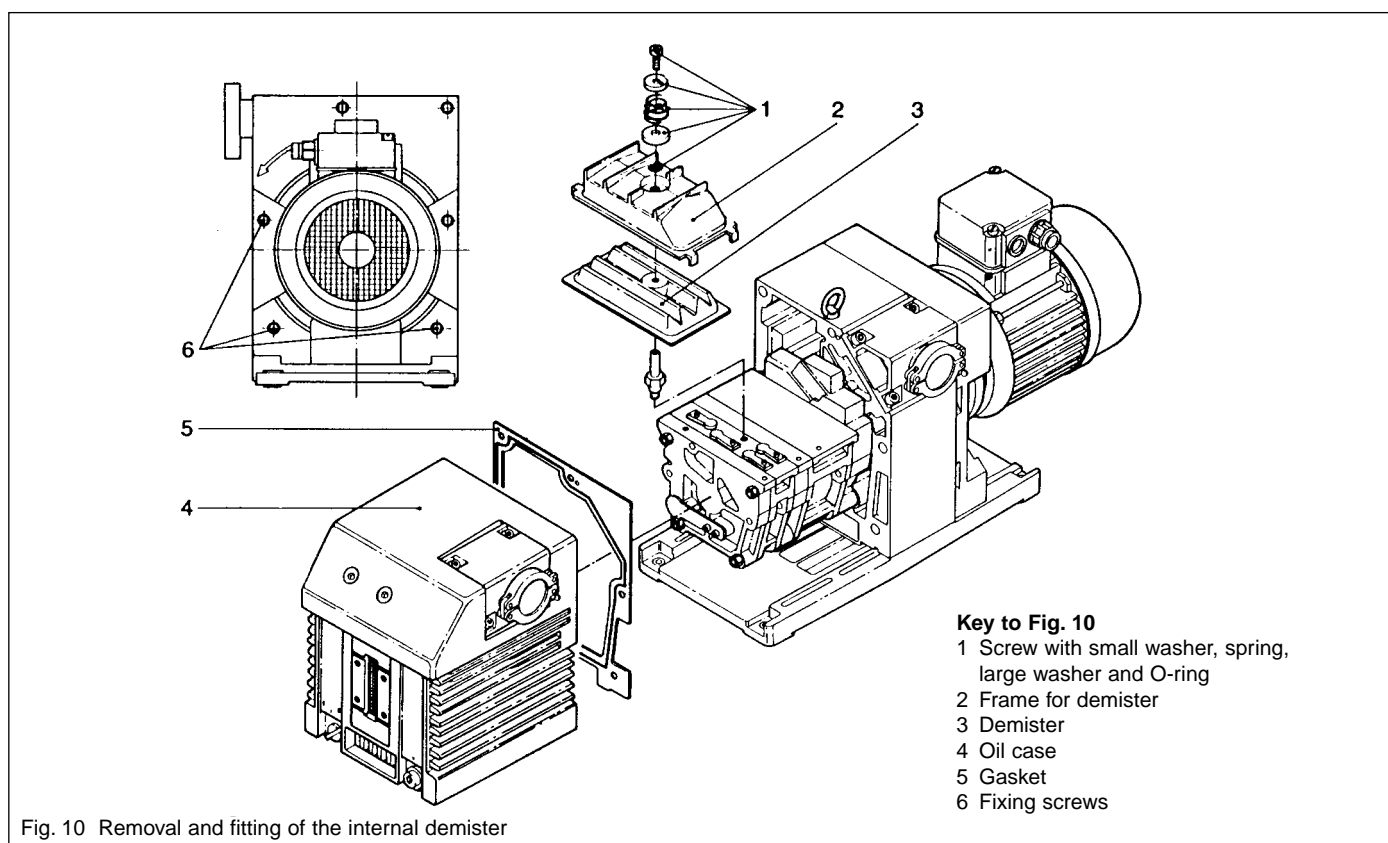

Fig. 10 Removal and fitting of the internal demister

3.4 Removing and Fitting the Internal Demister (not required for PFPE)

Required tools:

Allen keys size 6 and 8

Required spare parts:

Gasket for oil case 200 09 148
Internal demister: 390 26 014

The internal demister is spring-mounted in a frame. When it is clogged, it rises periodically to reduce the pressure difference created. The resultant noise at high intake pressures indicates that the internal demister is dirty.

Periodically clean or replace the internal demister; the maintenance interval depends on the application. Use a suitable solvent for cleaning.

Shutdown the pump and drain the oil (see Chapter 3.2).

Remove the **six recessed** screws (10/6) on the oil case (10/4). Don't remove the **non-recessed screws**; they hold the motor flange in place and need not be removed.

Pull the oil case forward off the pump.

Remove the gasket (10/5).

Unscrew screw (10/1).

Remove small washer (10/1), spring (10/1), large washer (10/1) and O-ring (10/1).

Lift off the frame (10/2) and remove the internal demister (10/3).

Clean all parts and check that they are in perfect condition; if not, replace them with new parts.

Reassemble in the reverse order.

Torque for the screws (10/6) is 12 Nm.

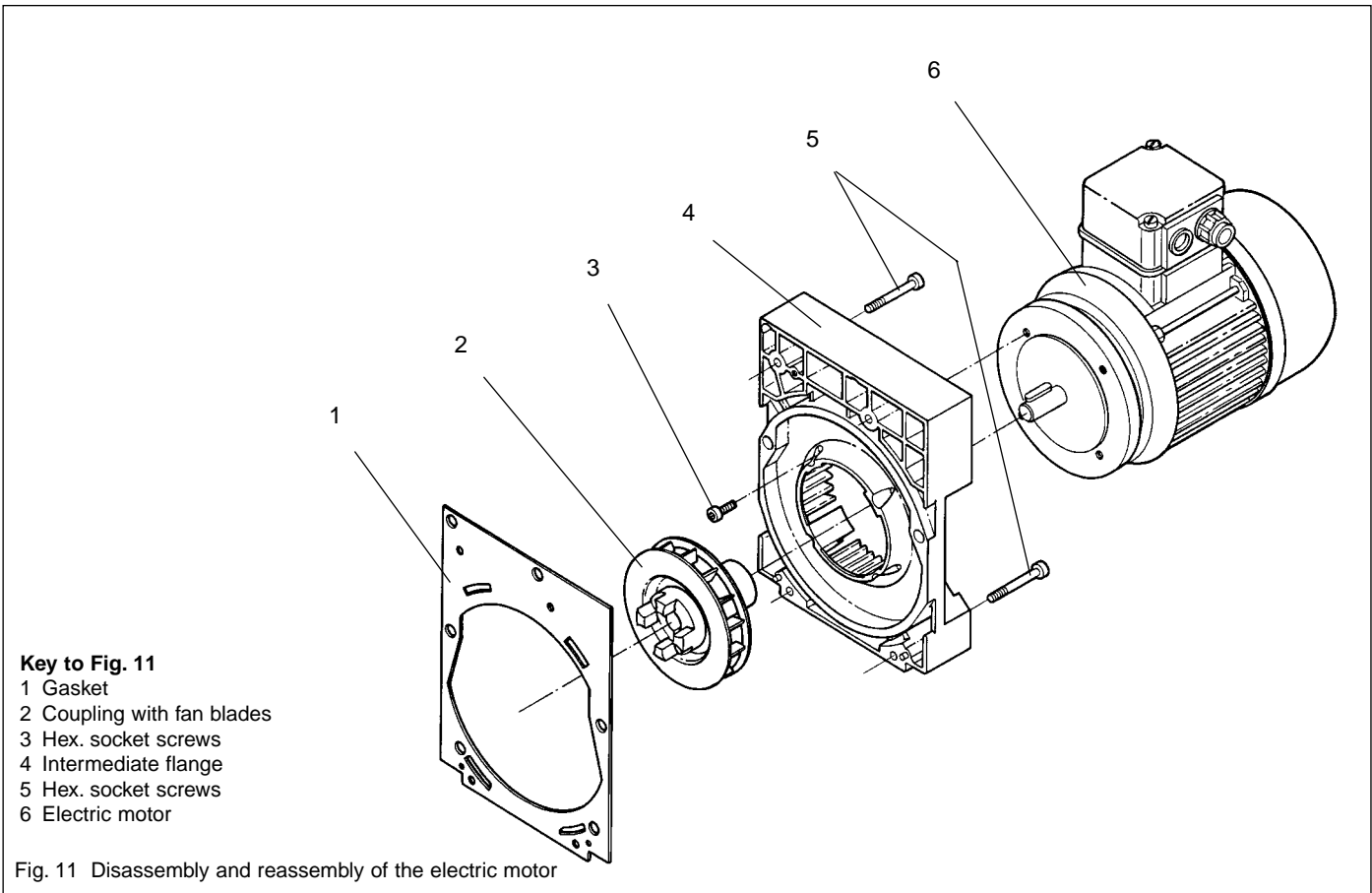

3.5 Disassembly and Reassembly of the Electric Motor

Warning Before starting any disassembly work, always disconnect the motor from the mains.
 Reliably prevent the pump from running up.



Required tools:

Screwdriver 1.0 x 5.5 mm (for junction box), open-jaw wrenches size 7 and size 19 (for junction box), Allan keys size 3 and size 6.

Possibly a puller for the coupling.

Disconnect the mains connection.

Support the motor.

Unscrew the four **non-recessed** hex. socket screws (11/5).

Remove the intermediate flange (11/4) together with the electric motor.

Remove the gasket (11/1).

Loosen the threaded pin and pull the coupling with the blade wheel (11/2) off the motor shaft.

Unscrew the hex. socket screws (11/3).

Remove the electric motor (11/6).

Clean all parts and check that they are in perfect condition; if not, replace them with new parts.

Reassemble in the reverse order.

Key to Fig. 12

- 1 Coupling element
- 2 Cylinder head screw
- 3 Spring washer
- 4 Coupling (one half)
- 5 Key
- 6 Compression ring
- 7 O-ring
- 8 Holding plate
- 9 Shaft seals
- 10 Centering disk
- 11 O-ring
- 12 Bushing
- 13 Bolts

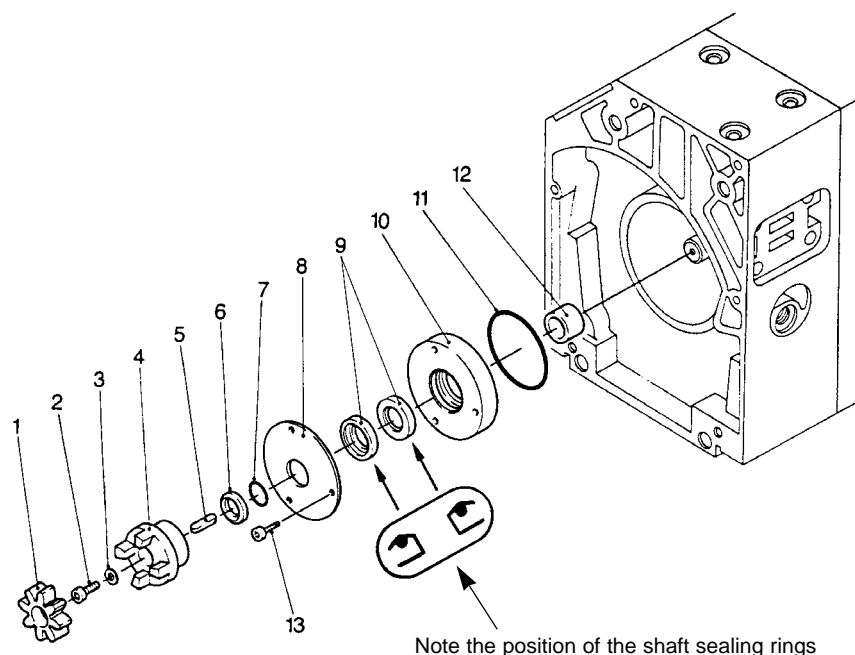

Fig. 12 Exchanging the shaft seal

3.6 Replacing the Outer Shaft Seal

Note Oil stains under the housing of the coupling indicate a worn shaft sealing ring. The shaft sealing ring may be exchanged without having to remove or disassemble the pump module.

Required tools:

Allen keys size 3, 5 and 8, flat-nose pliers, plastic hammer, shaft seal driver, possibly a puller for the coupling.

Required spare parts:

Shaft seal 239 53 007
 Bushing 231 92 034

Shutdown the pump.

Drain the oil (see Chapter 3.2).

Support the motor.

Unscrew the four **non-recessed** hex. socket screws (11/5) and remove the motor (11/6) with the intermediate flange.

Remove gasket (11/1).

Remove coupling element (12/1).

Unscrew screw (12/2) and pull off the spring washer (12/3).

Pull off the coupling half (12/4).

Remove key (12/5).

Pull off the compression ring (12/6) and O-ring (12/7).

Unscrew the hex. socket screws (12/13) and pull out the centering disc (12/8).

Pull the centering disk (10/12) out.

If the centering disc does not come loose, use the forcing thread into which screws (12/13) can be screwed in.

Remove the O-ring (12/11).

Force the shaft seal (12/9) out of the centering disk.

Pull off the bushing (12/12) from the shaft.

Note

We recommend the use of a new shaft seal and bushing for reassembly.

Before fitting the new shaft seal, moisten it slightly with a little vacuum pump oil.

Using a suitable plastic or aluminium cylinder (shaft seal driver) and a plastic hammer, force the shaft seal (12/9) carefully and without bending it into the centering disk (for position of shaft seal, see Fig. 12).

If you do not have a shaft seal driver, place the shaft seal on the centering disk and carefully force it in with light blows of the plastic hammer.

The shaft seal must not be bent.

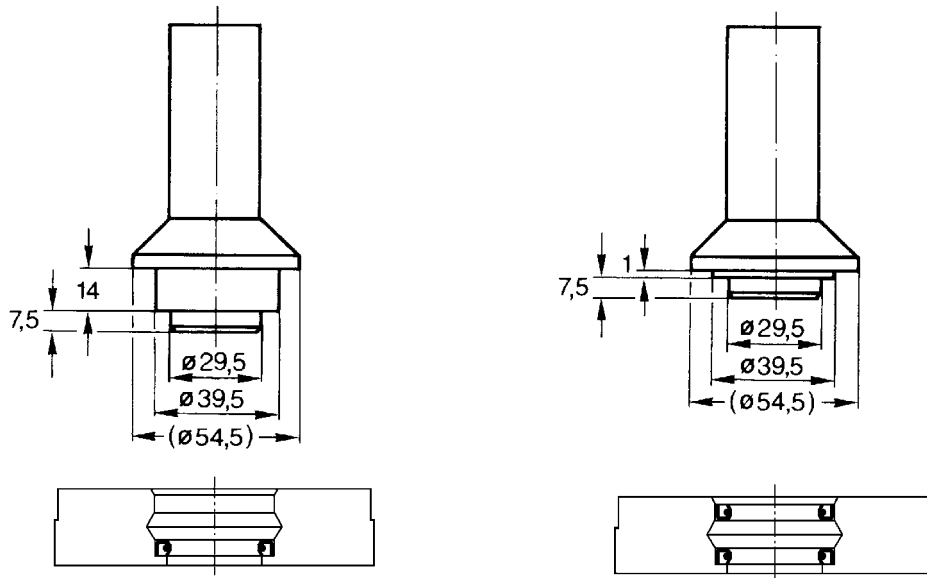

Fig. 13 Shaft sealing ring driver

Key to Fig. 13
 left: driver for the inner sealing ring
 right: driver for the outer sealing ring
 bottom: centering disk with shaft sealing ring

- Insert the O-ring (12/11) into its groove.
- Carefully push the centering disk (12/10) with the shaft seal onto the shaft and up against the end plate.
- Push the holding panel (12/8) on and tighten with bolts (12/13).
- Insert the busing (12/12) carefully at the center of the centering disk.
- Push the O-ring (12/7) and the compression disk (12/6) on to the shaft.
- Insert the key (12/5).
- Mount the pump-half of the coupling (12/4) on the shaft.
- Install the spring washer (12/3) and tighten the screw (12/2).
- Insert the coupling element (12/1) into the coupling and mount the motor (see Chapter 3.5).

3.7 Removing and Remounting the Pump Module

Required tools:

Allen keys size 3, 4, 6 and 8 mm, box wrench size 13, possibly pliers, torque wrench.

Required spare parts:

Gaskets: 239 73 039
 200 90 148

3.7.1 Removing the Pump Module

- Drain the oil and remove the oil case (see Chapter 3.4).
- Unscrew the hex. nuts (14/1).
- Pull the entire pump module (14/2) forward off the tie rods (14/5).

Key to Fig. 14

- 1 Hex. nuts
- 2 Pump module
- 4 Gasket
- 5 Coupling element
- 6 Tie rods

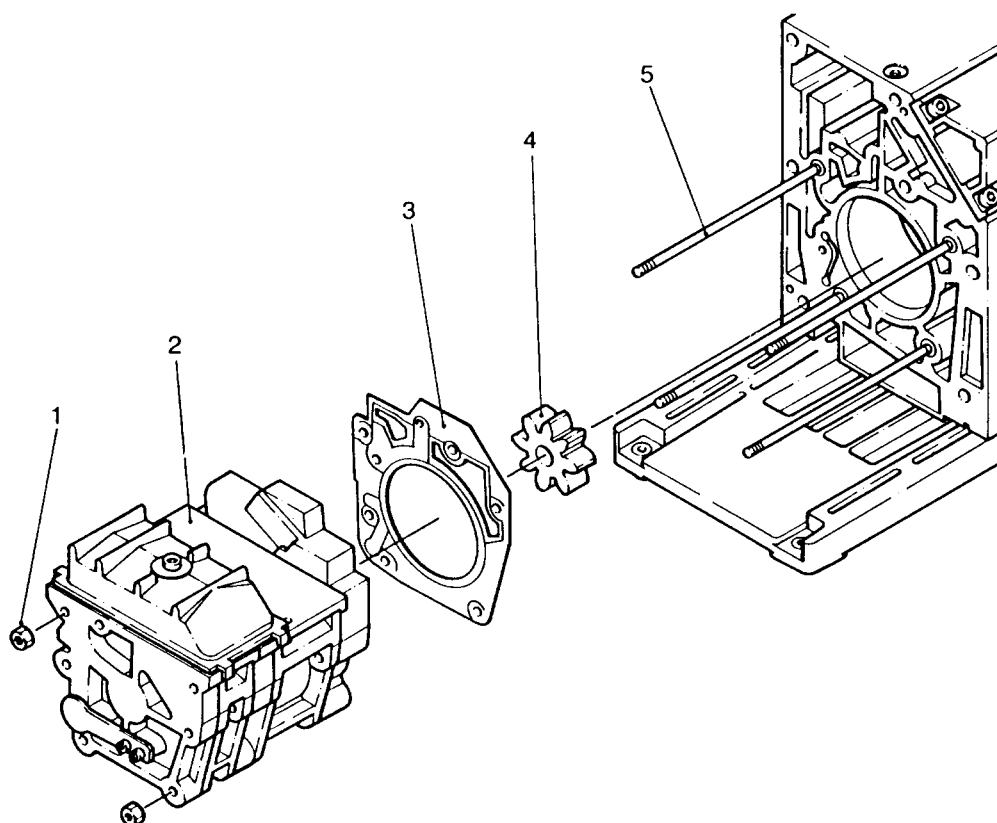

Fig. 14 Removing and remounting the pump module

Caution When doing so, ensure that the individual pin-fitted parts are not loosened. Further disassembly of the pump module should only be carried out by a trained service engineer.

Remove the gasket (14/3).

Remove the coupling element (14/4).

Caution After removing the protective shipping materials, handle the new pump module with care.

Before installing a new pump module, remove the four tie rods from the new module and insert them in the old one for protection during shipment.

3.7.2 Remounting the Pump Module

When installing a new pump module, it is also advisable to use a new gasket (14/3).

Check the coupling element (14/4) for damage; if necessary, install a new one.

Use the tie rods supplied with the new pump module only if the old ones are damaged. To do so, unscrew the old tie rods with lock nuts, and screw in the new ones. With the aid of the lock nuts, tighten the tie rods. Then remove the lock nuts.

Push the gasket (14/3) onto the tie rods (14/5), push the coupling element (14/4) onto one coupling half.

Push the entire pump module (new or repaired) onto the tie rods.

Screw on the hex. nuts (14/1) and carefully cross-tighten them (torque 17 Nm).

Mount the oil case together with the gasket (see Chapter 3.4).

Fill in oil.

3.8 Leybold Service

If a pump is returned to Leybold, indicate whether the pump free of substances damaging to health or whether it is contaminated. If it is contaminated also indicate the nature of the hazard. For this you must use a form which has been prepared by us which we will provide upon request.

A copy of this form is reproduced at the end of these Operating Instructions: "Declaration of Contamination of Vacuum Instruments and Components".

Please attach this form to the pump or enclose it with the pump.

This "Declaration of Contamination" is required to meet German Law and to protect our personnel.

Leybold must return any pumps without a "Declaration of Contamination" to the sender's address.

Warning The pump must be packed in such a way, that it will not be damaged during shipping and so that any contaminants are not released from the package.



3.8.1 Waste Disposal of Used Pump Materials

The corresponding environmental and safety regulations apply. This applies equally to used filters and filter elements (oil filter, exhaust filter and dust filter).

Warning – In the case of hazardous substances determine the kind of hazard first and observe the applicable safety regulations. If the potential hazard still persists, the pump must be decontaminated before starting with any maintenance work. For professional decontamination we recommend our Leybold service.



– Never exchange the oil or the filters while the pump is still warm. Let the pump cool down to uncritical temperatures first. You must wear suitable protective clothing.

3.9 Storing the Pump

Caution Before putting a pump into operation once more it should be stored in a dry place preferably at room temperature (20 °C = 68 °F). Before the pump is shelved it must be properly disconnected from the vacuum system, purged with dry nitrogen and the oil should be changed too.

The inlets and outlets of the pump must be sealed with the shipping seals which are provided upon delivery.

The gas ballast switch must be set to the "0" position and if the pump is to be shelved for a longer period of time it should be sealed in a PE bag containing some desiccant (silica gel).

When a pump is put into operation after it has been shelved for over one year, standard maintenance should be run on the pump and the oil should also be exchanged (see Operating Instructions). We recommend that you contact the Leybold service.

Key to the maintenance plan - see 3.10

- VE = Maintenance before switching on the system
- VP = Maintenance before starting production
- t = Daily maintenance
- 6m = Six monthly maintenance
- a = Annual maintenance
- n-a = Maintenance every n years.

We recommend that you service the pump every two years covering the following:

- Cleaning
- Checking of the individual components
- Exchange of all seals
- Functional check.

This check should be run by the Leybold service.

3.10 Maintenance Plan (Recommendation)

No.	Rotary vane pumps TRIVAC D 40 BCS TRIVAC D 65 BCS	Measurement/test quantity Operating/auxiliary materials	Interval						Remarks
			VE	VP	t	6m	a	n-a	
									Refer also to the Operating Instructions – Chapter: individual components.
1	Operate the pump for at least 0.8 hours with gas ballast.				x				Condensed water is thus removed from the oil.
2	Check the oil level, change the oil if required.	Oil: N 62 or special alternative oils (see Chapter 1.6.1)	x		x				Refill: only after the pump has been switched off.
3	Check the quality of the oil, change the oil if required.	visually chemically mechanically	x		x				Visually: normally light and transparent, oil change is required when discolorations increase. Chemically: to DIN 51558 when the neutralisation number exceeds 2; then an oil change will be required. Mechanically: when dynamic viscosity at 25 °C exceeds 240 mPas; then an oil change will be required. Disposal of waste oil: see Chapter 3.8.1.
4	Clean the dirt trap in the intake port, change it as required.	Suitable cleaning agent and compressed air.				x			<input type="checkbox"/> Clean dirt trap with a cleaning agent and blow it out with compressed air under a suction hood. <input type="checkbox"/> Replace the defective dirt trap. Use a cleaning agent which complies with the national / international specifications. Observe the safety regulations when using cleaning agents.
5	Clean the internal demister, change it as required.	Suitable cleaning agent.					x		Already clean before the maintenance interval has elapsed when the noise level increases. <input type="checkbox"/> Clean the internal demister using a cleaning agent. <input type="checkbox"/> Replace the defective internal demister. <input type="checkbox"/> Dispose of the defective internal demister as special waste. Cleaning agent according to national / international specifications. Observe the safety regulations when using cleaning agents.
6	Check the edges of the teeth on the coupling element for any damages, change the coupling element as required.							x	
7	Change the oil - and clean the oil level glass.	Oil: N 62 or special and alternative oils. See Chapter 1.6.1. Suitable cleaning agent and compressed air.						x	Oil change: • First oil change after 100 operating hours. • Pump switched off and cold. Change the oil when the pump is cold in order to avoid releasing absorbed gases. <input type="checkbox"/> Clean the oil level glass with a cleaning agent and blow it out with compressed air under a suction hood. Cleaning agent according to national / international specifications. Observe the safety regulations when using cleaning agents. Quantity of oil: see Operating Instructions, Chapter 1.7. Waste disposal of oil: see Operating Instructions, Chapter 3.8.1.
8	Check the fan of the pump and the motor as well as the cooling fins on the motor for deposits and clean as required.	Brush and industrial vacuum cleaner.						x	Already clean before the maintenance interval has elapsed when the pump or the motor gets too warm. Caution: switch off the pump and ensure that it can not run up inadvertently (disconnect from the mains).

4 Troubleshooting

Fault	Possible cause	Remedy	Repair*
Pump does not start.	Wiring is malfunctioning. Motor protection switch incorrectly set (3-phase motors only). Operating voltage does not match motor. Motor is malfunctioning. Oil temperature is below 12 °C. Oil is too viscous. Exhaust filter or exhaust line is clogged. Pump is seized up (sign: pump is jammed).	Check and repair wiring. Set motor protection switch properly. Replace the motor. Replace the motor. Heat the pump and pump oil or use different oil. Change the oil. Replace the filter or clean the exhaust line. Repair the pump.	- 2.3 3.5 3.5 2.5.3/3.2 3.2 - Service
Pump does not reach ultimate pressure.	Measuring technique or gauge is unsuitable. External leak ¹⁾ . Anti-suckback valve is malfunctioning. Exhaust valve is malfunctioning. Oil is unsuitable. Intake line is dirty. Pump is too small.	Use correct measuring technique and gauge. Measure the pressure directly at pump's intake port. Repair the pump. Repair the valve. Repair the valve. Change the oil (degas it, if necessary). Clean vacuum lines. Check the process data; replace the pump, if necessary.	- Service Service Service 3.2 - -
Pumping speed is too low.	Dirt trap in the intake port is clogged. Exhaust filter is clogged. Connecting lines are too narrow or too long.	Clean the dirt trap; Precaution: install a dust filter in intake line. Exchange the filter element. Use adequately wide and short connecting lines.	3.3 - 2.2
After switching off pump under vacuum, pressure in system rises too fast.	System has a leak. Anti-suckback valve is malfunctioning.	Check the system. Repair the valve.	- Service
Pump gets hotter than usually observed.	Cooling air supply is obstructed. Ambient temperature is too high. Process gas is too hot. Oil level is too low. Oil is unsuitable. Oil cycle is obstructed. Exhaust filter or exhaust line is obstructed. Exhaust valve is malfunctioning. Pump module is worn out.	Set pump up correctly. Set pump up correctly. Change the process. Add oil. Change the oil. Clean or repair the oil lines and channels. Replace the exhaust filter, clean the exhaust line. Repair the valve. Replace the pump module.	2.1 2.1/2.5.3 - 3.2 3.2 Service - Service 3.7
Oil in the intake line or in vacuum vessel.	Oil comes from the vacuum system. Anti-suckback valve is obstructed. Sealing surfaces of anti-suckback valve are damaged or dirty. Oil level is too high.	Check the vacuum system. Clean or repair the valve. Clean or repair the intake port and the anti-suckback valve. Drain the excess oil.	- Service Service 3.2
Oil is turbid.	Condensation.	Degas the oil or change the oil and clean the pump. Precaution: open the gas ballast valve or insert a condensate trap.	2.5.2/3.2
Pump is excessively noisy.	Oil level is much too low (oil is no longer visible). Silencing nozzle is clogged. Intake pressure is too high. Internal demister is clogged. Coupling element is worn. Vaness or bearings are damaged.	Add oil. Clean or replace the silencing nozzle. Lower the intake pressure. Clean or replace demister. Install new coupling element. Repair pump.	3.2 Service - 3.4 3.5 Service

* Repair information: refer to the Chapter in the Operation Instruction stated here.

1) Bubble test: the warm pump with degassed oil is running without gas ballast and the intake blanked off. The exhaust line is led in to a vessel with water. If an evenly spaced line of bubbles appears, then the pump has an external leak.

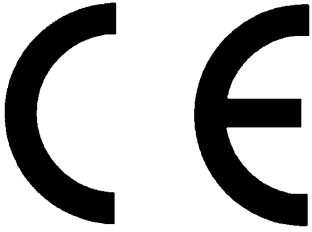

EC Declaration of Conformity

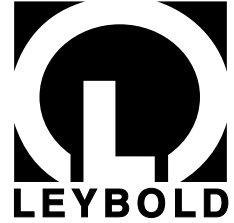

We – LEYBOLD Vakuuum GmbH – herewith declare that the products defined below meet the basic requirements regarding safety and health of the relevant EC directives by design, type and versions which are brought into circulation by us.

In case of any product changes made without our approval, this declaration will be void.

Designation of the products: Rotary vane pump

Types: TRIVAC BCS D 40 BCS
D 65 BCS

Cat. Nos.: 113 88
113 89
113 97
113 98
113 99
154 52
154 54

The products conform to the following directives:

- EC Directive on Machinery (98/37/EG)
- EC Directive on Low-Voltages (73/23)+(93/68/EWG)
- EC EMC Directive (89/336/EWG)
(91/263/EWG) + (92/31/EWG) + (93/68/EWG)

Applied harmonised standards:

- DIN EN 292 Part 1 11.91
- DIN EN 292 Part 2 06.95
- DIN EN 1012 Part 2 07.96
- DIN EN 60 204 Part 1 11.98

Applied national standards and technical specifications:

- DIN 31 001 April 1983

Cologne, May 30, 2001

K. Kilian, Business Area Manager LPV
Division Industrial

Cologne, May 30, 2001

Dr. Bahnen, Head of R&D LPV
Division Industrial



Declaration of Contamination of Compressors, Vacuum Pumps and Components

The repair and / or servicing of compressors, vacuum pumps and components will be carried out only if a correctly completed declaration has been submitted. Non-completion will result in delay. The manufacturer can refuse to accept any equipment without a declaration. A separate declaration has to be completed for every single component.

This declaration may be completed and signed only by authorised and qualified staff.

Customer/Dep./Institute: _____
Address: _____
Person to contact: _____
Phone: _____ **Fax:** _____
Order number of customer: _____

Reason for returning the item/s

A. Description of the equipment (machine or component)

Type: _____
Catalogue number: _____
Serial number: _____
Type of oil used: _____

Ancillary equipment

B. Condition of the equipment (machine or component)

	Yes	No	Not known
1. Has the equipment been used	<input type="checkbox"/>	<input type="checkbox"/>	<input type="checkbox"/>
2. Drained (product/service fluid)	<input type="checkbox"/>	<input type="checkbox"/>	<input type="checkbox"/>
3. All openings sealed airtight	<input type="checkbox"/>	<input type="checkbox"/>	<input type="checkbox"/>
4. Purged:	<input type="checkbox"/>	<input type="checkbox"/>	<input type="checkbox"/>
Cleaning agent: _____			
Method of cleaning: _____			

C. Description of processes / substances (Please fill in absolutely)

1. What substances have come into contact with the equipment:
 Trade name, chemical name of liquids, solids and substances processed, properties of the substances according to safety data sheet (toxic, inflammable, corrosive, radioactive)

	Trade name:	Chemical name:	Properties:
a)			
b)			
c)			
d)			

2. Are these substances harmful? Yes No Not known
3. Dangerous decomposition products when thermally loaded Yes No Not known
- Which: _____

Components contaminated by micro biological, explosive or radioactive products will not be accepted without written evidence of decontamination.

D. Legally binding declaration

I/we hereby declare that the information supplied on this form is accurate and sufficient to judge any contamination level.

Name of authorised person (block letters): _____

_____ date _____ signature of authorised person _____ firm stamp

Copies: Page 1 (white) to manufacturer or representative – Page 2 (yellow) attach to consignment packaging securely – Page 3 (blue) copy for file of sender

Sales Net worldwide

AMERICA

USA:

LEYBOLD VACUUM USA
5700 Mellon Road
Export, PA 15632
Phone: +1-724-327 57 00
Fax: +1-724-733 12 17
Internet: <http://www.leyboldvacuum.com>

Canada:

LEYBOLD Canada Inc.
7050 Telford Way, Unit 5
Mississauga, Ontario
Canada L5S 1V7
Phone: +1-905-672 77 04
Fax: +1-905-672 22 49
e-mail:
reachus@leybold.on.ca

EUROPE

Deutschland:

LEYBOLD VAKUUM
GmbH
Bonner Straße 498
D-50968 Köln
Phone: +49-221-347-1234
Fax: +49-221-347-1245
Internet: www.leyboldvac.de
e-mail:
sales@leyboldvakuum.com

Belgien/Niederlande/

Luxemburg:
LEYBOLD N.V.
Leuvensesteenweg 542, 9A
B-1930 Zaventem
Phone: +32-2-71 10 083
Fax: +32-2-72 08 338

LEYBOLD B.V.

Computerweg 7
NL-3606 AV Maarssen
Phone: +31-346-583 999
Fax: +31-346-583 990

Frankreich:

LEYBOLD S.A.
7, Avenue du Quebec
Z.A. de Courtaboeuf, B.P. 42
F-91942 Courtaboeuf Cedex
Phone: +33-1-6982 48 00
Fax: +33-1-6907 57 38
e-mail:
Compuserve:100635,43

Groß-Britannien/Irland:

LEYBOLD LTD.
Waterside Way,
Plough Lane
GB-London SW 17 OHB
Phone: +44-208-971 70 00
Fax: +44-208-971 70 01

Italien:

LEYBOLD S.P.A.
Via Trasimeno 8
I-20128 Milano
Phone: +39-02-27 22 31
Fax: +39-02-27 20 96 41

Spanien:

LEYBOLD S.A.
C/. Mataró, 27
Polígono Industrial Les
Grases
E-08980 Sant Feliu de
Llobregat (Barcelona)
Phone: +34-93-666 46 16
Fax: +34-93-666 43 70

Schweden:

LEYBOLD AB
Box 9084
40092 Göteborg
Phone: +46-31-68 84 70
Fax: +46-31-68 39 39

Schweiz/ Liechtenstein:

LEYBOLD AG
Leutschenbachstraße 55
CH-8050 Zürich
Phone: +41-1-308 40 50
Fax: +41-1-302 43 73

ASIA

Volksrepublik China:

LEYBOLD (Tianjin)
VACUUM EQUIPMENT
MANUFACTURING Co.,
Ltd.
Beichen Economic Develop-
ment Area (BEDA)
Tianjin 300400, China
Phone: +86-22 26 972 016
Fax: +86-22 26 972 017
e-mail:
leybold@public.tpt.tj.cn

Japan:

LEYBOLD Co., Ltd.
Head Office
Tobu A.K. Bldg. 4th Floor
23-3, Shin-Yokohama 3-
chome
Kohoku-ku, Yokohama-shi
Kanagawa ken 222-0033
Phone: +81-45-471 33 30
Fax: +81-45-471 33 23

Korea:

LEYBOLD Korea Ltd.
4th Fl. Shinan Bldg., 173-1
Jangchoog-dong 2ga,
Choong-ku
Seoul 100-392, Korea
C.P.O. Box 709

Phone: +82-2-227 11 567
Fax: +82-2-227 11 568

Singapore:

BALZERS and LEYBOLD
Singapore Pte. Ltd.
1 Tuas South Street 3
Singapore 638043
Phone: +65-865 18 65
Fax: +65-862 22 95

Taiwan:

LEYBOLD Taiwan, Ltd.
2 F, No 416-1, Sec. 3
Chung-Hsin Rd.
Chu Tung, Hsinchu.
Taiwan R.O.C: 310
Phone: +886-3-583 39 88
Fax: +886-3-583 39 99



LEYBOLD VACUUM GmbH

Bonner Strasse 498 (Bayenthal)
D-50968 Cologne
Tel.: +49(0)221 347-0
Fax: +49(0)221 347-1250
<http://www.leyboldvac.de>
e-mail: documentation@leyboldvac.de