



HiPace[®] 300 with TC 400, DN 100 ISO-K



Similar Image

HiPace® 300 with TC 400, DN 100 ISO-K

- Rugged, powerful turbopump with a pumping speed of up to 260 l/s for N₂
- Integrated TC 400 drive electronics
- Ideal for analytical and industrial applications
- For installation in any orientation
- With integrated water cooling for maximum gas throughput
- Flexible through the ability to employ up to 4 accessories
- Ideal for fast cycles
- Extensive accessories expand the range of applications

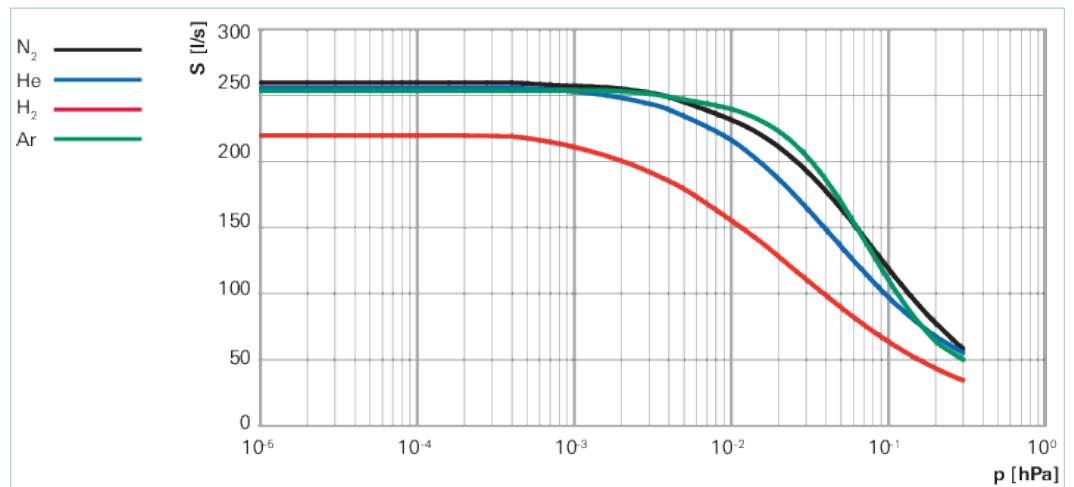

Dimensions

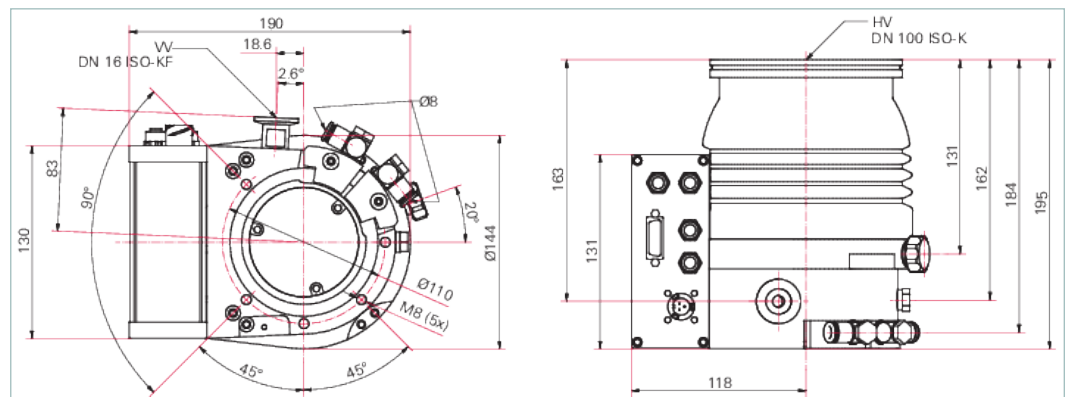

Technical Data	HiPace® 300 with TC 400, DN 100 ISO-K
Bearing	Hybrid
Compression ratio for Ar	$> 1 \cdot 10^{11}$
Compression ratio for H ₂	$9 \cdot 10^5$
Compression ratio for He	$> 1 \cdot 10^8$
Compression ratio for N ₂	$> 1 \cdot 10^{11}$
Connection flange (in)	DN 100 ISO-K
Connection flange (out)	DN 16 ISO-KF/G ¼"
Cooling method	Water
Cooling method, optional	Air
Cooling water flow	50 l/h
Cooling water flow, max.	50 l/h
Cooling water flow, min.	50 l/h

Technical Data	HiPace® 300 with TC 400, DN 100 ISO-K
Cooling water temperature	15-35 °C 59-95 °F 288-308 K
Current, max.	12,5 A
Electronic drive unit	with TC 400
Final pressure	$< 1 \cdot 10^{-7}$ hPa $< 7.5 \cdot 10^{-8}$ Torr $< 1 \cdot 10^{-7}$ mbar
Fore-vacuum max. for N ₂	20 hPa 15 Torr 20 mbar
Gas throughput at final rotation speed for Ar	7 hPa·l/s
Gas throughput at final rotation speed for H ₂	> 14 hPa·l/s
Gas throughput at final rotation speed for He	20 hPa·l/s
Gas throughput at final rotation speed for N ₂	14 hPa·l/s
I/O interfaces	RS-485, Remote
Interfaces, extended	Profibus DeviceNet E74
Mounting orientation	Arbitrary
Permissible radial magnetic field max.	5.5 mT
Power consumption max.	300 W
Pumping speed for Ar	255 l/s
Pumping speed for H ₂	220 l/s
Pumping speed for He	255 l/s
Pumping speed for N ₂	260 l/s
Rotation speed ± 2 %	60,000 rpm 60,000 min ⁻¹
Rotation speed variable	35 – 100 %
Run-up time	1.8 min
Sound pressure level	≤50 dB(A)
Venting connection	G 1/8"
Weight	6.7 kg 14.77 lb

Order number	
HiPace® 300	PM P03 900

Accessories	
Adapters (electrical) Profibus	
Remote adapter for RS-485	PM 061 649 -X
Adapters (electrical) Remote	
Y-Connector, shielded, M12 for accessories	P 4723 013
Supply socket TC 400/TM 700, straight	P 4723 100
Supply bushing, angled, for TC 400/TM 700	P 4723 101
Adapters (electrical) RS-232/485	
Y-connector M12 for RS-485	P 4723 010
USB RS-485 converter	PM 061 207 -T
Coupling M12 for RS-485	PM 061 270 -X
Terminal resistor for RS-485	PT 348 105 -T
Power separator for RS-485	PT 348 132 -T
Cables Backing pump control cables	
Control cable for pumping stations 0.7 m	PM 061 675 AT
HiPace – ACP connection cable	PM 071 142 -X
Cables Connection cables	
Connection cable for HiPace with TC 400/TM 700 to power supply pack TPS/DCU 310/311/400/401	PM 061 352 -T
Cables Extension cables	
Extension cable M12 on M12	PM 061 747 -T
Cables Mains cables / Power cords	
Mains cable 230 V AC, CEE 7/7 to C13, 3 m	P 4564 309 ZA
Mains cable 115 V AC, NEMA 5-15 to C13, 3 m	P 4564 309 ZE
Mains cable 208 V AC, NEMA 6-15 to C13, 3 m	P 4564 309 ZF
Cables RS-485 Interface cables	
Interface cable, M12 m straight / M12 m straight, 3 m	PM 061 283 -T
Interface cable, M12 m straight / M12 m angled, 0.7 m	PM 061 791 -T
Connections Connection kits for mounting of pumps	
Connection kit for mounting of pumps, DN 16 ISO-KF	120SWS016-1000
Control Devices Backing pump	
Relay box for backing pumps, single phase 20 A for TC 400 and TCP 350, M12 plug	PM 061 375 -T
Relay box, shielded, for backing pumps, 1-phase 7 A for TC 400/1200, TM 700 and TCP 350, M12	PM 071 284 -X
Control Devices Power supplies and control displays	
Accessories package for HPU 001/PC	PM 061 005 -T
TPS 310, power supply pack for wall/standard rail fitting	PM 061 342 -T
TPS 311, power supply pack 3HU 19" rack module	PM 061 346 -T
Front panel kit for TPS 311	PM 061 395 -T
OmniControl 001, rack unit without integrated power supply pack	PE D42 100 0
OmniControl 001 Mobile, control units	PE D22 000 0
OmniControl 300, rack unit with integrated power supply pack	PE D62 110 0
OmniControl 300, table unit with integrated power supply pack	PE E62 110 0
Cooling Air cooling	
Air cooling for HiPace 300 with TC 400	PM Z01 302
Air cooling for HiPace 300, 115 V	PM Z01 308
Air cooling for HiPace 300, 230 V	PM Z01 309

Accessories	
Monitoring Pressure Sensors	
OmniControl 200 mit PKR 361, 40 CF	PT 440 957 -T
Monitoring Sealing gas monitoring units	
Sealing gas monitoring unit G 1/8"	PM 016 911 -U
Mounting DN ISO-K, Mounting kits, bracket screws	
Mounting kit for HiPace 300 with DN 100 ISO-K, including coated centering ring and bracket screws	PM 016 365 -T
Mounting kit for HiPace 300, DN 100 ISO-K, including coated centering ring, splinter shield and bracket screws	PM 016 366 -T
Mounting kit for HiPace 300, DN 100 ISO-K, including coated centering ring, protection screen and bracket screws	PM 016 367 -T
Mounting DN ISO-K/-F, sealings	
Centering ring with multifunction coating, DN 100 ISO-K/-F	PM 016 210 -U
Mounting DN ISO-K/-F Mounting kits	
Mounting kit for DN 100 ISO-K to ISO-F, with collar flange, coated centering ring, hexagon bolts	PM 016 940 -T
Mounting kit for DN 100 ISO-K to ISO-F, with collar flange, coated centering ring with splinter shield, hexagon bolts	PM 016 941 -T
Mounting kit for DN 100 ISO-K to ISO-F, with collar flange, coated centering ring with protection screen, hexagon bolts	PM 016 942 -T
Mounting kit for DN 100 ISO-K to ISO-F, with collar flange, coated centering ring, stud screws	PM 016 945 -T
Mounting kit for DN 100 ISO-K to ISO-F, with collar flange, coated centering ring with splinter shield, stud screws	PM 016 946 -T
Mounting kit for DN 100 ISO-K to ISO-F, with collar flange, coated centering ring with protection screen, stud screws	PM 016 947 -T
Protection DN ISO-K/-F, sealings, splinter shields, protection screens	
Centering ring with multifunction coating and integrated splinter shield, DN 100 ISO-K/-F	PM 016 211 AU
Centering ring with multifunction coating and integrated protection screen, DN 100 ISO-K/-F	PM 016 212 AU
Protection Sealing gas throttles	
Sealing gas throttle for HiPace 300	PM Z01 317
Valves Fore-vacuum safety valves	
TVV 001, fore-vacuum safety valve, 230 V AC	PM Z01 205
TVV 001, fore-vacuum safety valve, 115 V AC	PM Z01 206
Valves Isolation valves	
HV gate valve, DN 100 ISO-F, electro-pneumatic, PI (RS)/PV 24 V DC, SS/FKM	GVP-S08342
Valves Sealing gas valves, shielded (normally closed)	
Sealing gas valve, shielded for HiPace 300 with TC 400 and TM 700, TCP 350	PM Z01 312
Venting Power failure venting units (normally open)	
Power failure venting valve, shielded, 24 V DC, G 1/8" for connection to TC 400, TM 700 and TC 1200	PM Z01 331

Accessories	
Venting Venting accessories	
Flange with pipe thread, DN 16 ISO-KF, G 1/8"	PM 016 780 -T
Push-in fitting for 6 mm tube, G 1/8"	PM 016 781 -T
Push-in fitting for 8 mm tube, G 1/8"	PM 016 782 -T
Hose nozzle for 9 mm hose, G 1/8"	PM 016 783 -T
Banjo fitting	PM 016 787 -T
Screw-in flange, DN 10 ISO-KF, G 1/8"	PM 033 737 -T
Banjo fitting, small	PM 143 877 -T
TTV 001, Drier for venting turbopumps	PM Z00 121
Venting Venting valves (normally closed)	
Venting valve, shielded, 24 V DC, G 1/8", for connection to TC 400/1200 and TM 700	PM Z01 291
Venting valve, shielded, 24 V DC, G1/8" for connecting to TC 400, 1200 as well as TM 700 with an 270° angled plug	PM Z01 292
Vibration Reduction Vibration dampers	
Vibration damper for HiPace 300/400, DN 100 ISO-K/F	PM 006 459 AX

VACUUM SOLUTIONS FROM A SINGLE SOURCE

Pfeiffer Vacuum stands for innovative and custom vacuum solutions worldwide, technological perfection, competent advice and reliable service.

COMPLETE RANGE OF PRODUCTS

From a single component to complex systems:

We are the only supplier of vacuum technology that provides a complete product portfolio.

COMPETENCE IN THEORY AND PRACTICE

Benefit from our know-how and our portfolio of training opportunities!

We support you with your plant layout and provide first-class on-site service worldwide.

Are you looking for a
perfect vacuum solution?
Please contact us:

Pfeiffer Vacuum GmbH
Headquarters · Germany
T +49 6441 802-0
info@pfeiffer-vacuum.de

www.pfeiffer-vacuum.com

All data subject to change without prior notice.

PFEIFFER  **VACUUM**