

DIGIVAC Customization Project Overview

105 Church St. Unit B
Matawan
New Jersey, 07747
(732) 765-0900
sales@digivac.com
www.digivac.com

Designing innovative vacuum gauges and controllers for over 30 years

CUSTOMIZATION OVERVIEW: VACUUM CONTROL RAMP RATE

PROBLEM STATEMENT:

Our customer reached out looking for a way to automate their process in order to avoid sucking their flour like substance into their vacuum pumps during initial evacuation. Using our existing technology with a few modifications, we were able to achieve a very slow initial evacuation using a ramp rate of 126 Torr/hour so as not to disturb their material of interest, while achieving an ultimate vacuum below 100 microns all automatically. Before getting help from the DigiVac team, the client manually turned valves to achieve the vacuum ramp rate that begins the process.

APPROACH:

The DigiVac design team formulated a simple system to *automatically control* a steady vacuum down to 2 Torr, then to 200 milliTorr using a customized Model 450 and off the shelf 801w2c. The Model 450 is a vacuum level controller that maintains a particular vacuum in a chamber between 1 and Atmosphere (760 Torr/mmHg) using a proportional valve. The design team customized the software to Ramp down the pressure rather than regulate to a particular vacuum. In addition, an off the shelf Model 801w2c was used to turn on a 2" solenoid valve and then a blower to complete the process all while not disturbing the flour-like substance in the chamber.

RESULTS:

Using the Model 801w2c panel mount gauge with SPDT Controls and a modified Model 450 vacuum Level Controller together allowed the customer to maintain a Ramp-Rate instrument automatically without disturbing the substrate in the chamber.

Functional Procedure

- 1) Switch 450 to "Ref"
- 2) Turn on Vacuum Pump
- 3) 450 slowly applies a vacuum at a ramp rate of 126 Torr/Hour
- 4) At 2 Torr, 2 inch solenoid valve opened up
- 5) At below 500 mT blower turns on
- 6) After sufficient time, user turns 450 to "purge" which slowly bleeds air back into system
- 7) At above 500 mT, blower turns off
- 8) At above 2 Torr Gate Valve closes
- 9) User can turn off Vacuum pump after gate valve closed
- 10) User removes product

Customized RAMP Vacuum Instrument Solution: Model 801W2C panel mount gauge with SPDT Controls and a modified Model 450 Vacuum Level Controller

User Procedure

- 1) Switch 450 to "Ref"
- 2) Turn on Vacuum Pump
- 3) Allow system to proceed
- 4) Switch 450 to "Purge"
- 5) Allow system to bleed up to Atmosphere
- 6) Remove Product

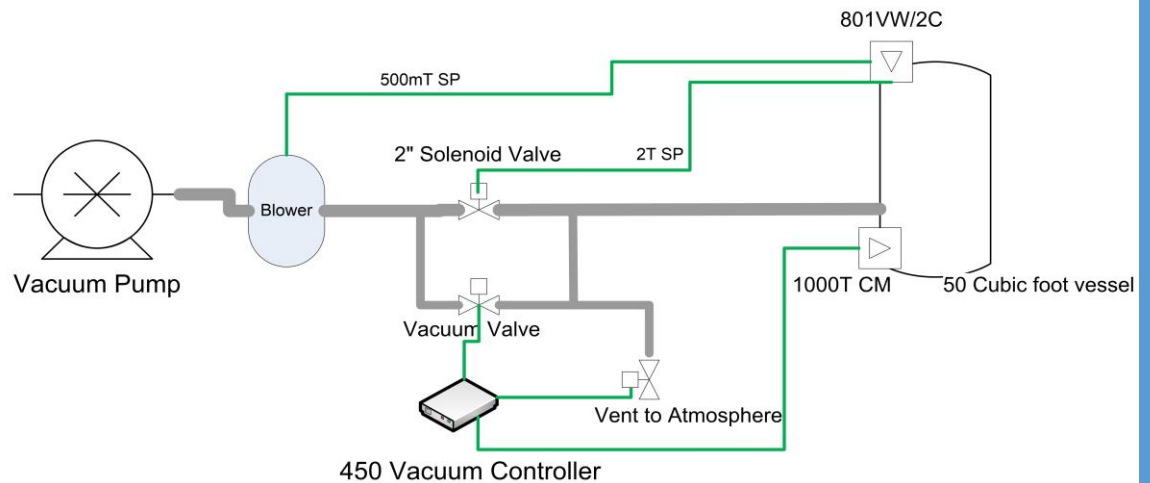

CONCLUSION:

- The client's needs for a Ramp-Rate Vacuum process were successfully automated by designing a process that utilized a Model 450 with modified software and our current Model 801W2C, which allowed for a quick turn-around for the client eliminating the addition of expensive controls and integration costs
- This customized solution was accomplished in 6 weeks time from needs assessment to product delivery
- The DigiVac Design advantage delivers a wealth of vacuum engineering knowledge at your disposal to develop innovative products that meet your specific needs
- Call us today to determine how we can meet your needs!

